

---

**OPERATING MANUAL**  
**ThermoGrip® Induction unit**  
**ISG4410WK-HL**  
**Software version: 3.5 and higher**

5118916



Bilz Werkzeugfabrik GmbH & Co. KG • Vogelsangstrasse 8 • 73760 Ostfildern • Germany  
Phone +49 (711) 34801-0 • Fax +49 (711) 348-1256

---

## Contents

<b>1</b>	<b>Product liability and warranty</b>	<b>5</b>
1.1	General	5
1.2	Warranty	5
1.3	Intended purpose	6
1.4	Service	7
1.5	Symbols and Pictograms	7
<b>2</b>	<b>Safety</b>	<b>8</b>
2.1	Selection of the installation site	8
2.2	Risks relating to electrical energy	8
2.3	Risks from hot parts	9
2.4	Protecting the chuck against overheating	9
2.5	Risks relating to electromagnetic radiation	10
2.6	Special risks	10
<b>3</b>	<b>Controls and commissioning ISG4410WK-HL</b>	<b>11</b>
3.1	Assembly	11
3.2	Setting up the ISG4410WK-HL	11
3.2.1	Mounting the non-swiveling guide unit	12
3.2.2	Mounting the swiveling guide unit	12
3.2.3	Mounting the connector unit	13
3.2.4	Mounting the support bracket and aligning the associated coil	14
3.3	Connecting the guide unit	14
3.4	Connecting the compressed air supply	15
3.5	Power supply of ISG4410WK-HL	15
<b>4</b>	<b>Operating the ISG4410WK-HL</b>	<b>16</b>
4.1	Operating buttons	16
4.2	Display	16
4.3	Switching on the device	17
4.4	Switching off the device	17
<b>5</b>	<b>Shrinking</b>	<b>18</b>
5.1	Basic shrink-fitting information	18
5.2	Work sequences when clamping, releasing or changing a tool	19
5.2.1	General advices	19
5.2.2	Clamping	20
5.2.3	Releasing	20
5.3	Change the ferrite disc	20
5.4	Change the coil	21
5.4.1	Dismantle the coil	21
5.4.2	Fitting the coil	21
5.5	Shrink-fit operating modes	22
5.5.1	ThermoGrip® clamping chucks: PARAMETER	23

---

5.5.1.1	Table of factory defined parameters.....	25
<b>5.5.2</b>	<b>Shrinking with free “Parameter” selection: MANUAL .....</b>	<b>27</b>
5.5.2.1	Special shrinking: Inverse shrinking (shrinking from the bottom) .....	30
5.5.2.2	Inverse shrinking-in.....	30
5.5.2.3	Inverse shrinking-out .....	31
5.5.2.4	Inverse shrinking tool change.....	31
5.5.2.5	Shrinking with coil limit stop ISGF3414 .....	31
<b>5.5.3</b>	<b>Define your own Parameters: TOOL MEMORY .....</b>	<b>32</b>
5.5.3.1	Setup TOOL MEMORY at the machine .....	32
5.5.3.2	Setup or change your own parameters externally (option).....	33
5.5.3.3	Select your own tool parameters .....	33
<b>5.5.4</b>	<b>List of most used tools: FAVORITES.....</b>	<b>34</b>
<b>6</b>	<b>Configuration .....</b>	<b>35</b>
6.1	Switching between mm/ inch .....	36
6.2	Setting up and configuration of cooling time.....	36
6.2.1	Setting up of cooling time .....	36
6.2.2	Configuration of cooling time .....	37
6.2.2.1	Configuration of cooling time for “parameter shrinking” .....	37
6.2.2.2	Configuration of cooling time for “manual shrinking” .....	37
6.3	Enter Start Delay .....	38
6.4	Enter Stop Delay .....	38
6.5	Read customized parameters .....	38
6.6	Password on/ off or change .....	39
6.7	Reset list of favorites.....	39
6.8	Lock shrinking operations .....	40
6.9	Write the tool memory onto an USB memory stick.....	40
6.10	Reset tool memory.....	40
<b>7</b>	<b>Service .....</b>	<b>41</b>
<b>8</b>	<b>Cleaning and Servicing .....</b>	<b>42</b>
8.1	Maintenance / Visual Inspection.....	42
8.2	Cleaning.....	42
8.2.1	Checking the cooling emulsion.....	42
8.3	Filling the coolant tank.....	43
8.4	Draining the coolant tank.....	43
8.5	Checking the float switch.....	43
8.6	Replacing the float switch.....	43
<b>9</b>	<b>Contacting the Manufacturer .....</b>	<b>44</b>
<b>10</b>	<b>Appendix .....</b>	<b>45</b>
10.1	Error messages and corrective measures.....	45
10.2	Technical data .....	49
10.3	Scope of supply .....	50
10.3.1	Available additions and optional accessories .....	51
10.3.2	Length pre-setting for ThermoGrip® chucks .....	54
10.3.3	Ejecting broken tools.....	54
10.3.4	Service pump.....	54

---

---

<b>10.4 Instructions Safety Glove.....</b>	<b>55</b>
<b>10.5 Mains Connections.....</b>	<b>56</b>
<b>10.6 EC Declaration of Conformity.....</b>	<b>57</b>
<b>10.7 Safety Data Sheets.....</b>	<b>58</b>
<b>10.7.1 Synergy 905.....</b>	<b>58</b>
<b>10.7.2 Techniclean MTC 43.....</b>	<b>62</b>
<b>10.8 Table of Fuses for 400V units.....</b>	<b>71</b>
<b>10.9 Table of Fuses for 480V units.....</b>	<b>71</b>
<b>10.10 Wiring diagrams.....</b>	<b>72</b>
<b>10.10.1 ISG4410WK-HL-400V.....</b>	<b>72</b>
<b>10.10.2 ISG4410WK-HL-480V.....</b>	<b>74</b>
<b>10.11 Pneumatic plan ISG4410WK-HL.....</b>	<b>76</b>

## 1 Product liability and warranty

### 1.1 General

These operating instructions are part of the technical documentation for the ThermoGrip® induction device ISG4410WK-HL.

These operating instructions are important so that the device can be used safely, correctly and efficiently. Observing these instructions will help to avoid risks, repair costs and downtimes, and will raise the general level of performance and the lifespan of the machine. The contents correspond to the constructional status of the ISG4410WK-HL at the time these operating instructions were compiled. The construction and technical data is subject to changes due to continuous further developments and for customized models.

Therefore no claims may be made on the basis of the content of these operating instructions (details, charts, drawings, descriptions etc.). Subject to errors!

These operating instructions, in particular the Chapter 2, Safety, page 8, must be read and observed by all persons who work with the device:

#### **Operation**

**Including tooling, troubleshooting whilst working, clearing production waste, machine care, disposal of operating supplies and materials**

#### **Maintenance**

**Servicing, inspection, repairs**

#### **Transport**

**In addition to the operating instructions and the accident prevention regulations relevant in the country and the place where the device is used, the recognized technical rules relating to safe and professional work and the respective workshop-specific regulations must be observed.**

If you have any questions, please do not hesitate to call us.

You can contact us at the address stated above.

If the reader discovers any printing errors, ambiguous information or inaccurate information in these operating instructions, please let us know.

### 1.2 Warranty

It is expected that the device will remain fully functional and safe. It is also expected that it will work accurately for many years, however this is only possible if the regulations governing the operation, maintenance, and repairs are observed in accordance with the manufacturer's guidance.

Any faults that occur during the warranty period will be remedied as defined in our warranty conditions. Unauthorized modifications and changes will immediately expire the manufacturer's warranty and all claims resulting from these will be the responsibility of the machine owner. This applies especially for those modifications that impair the safety of the device.

Warranty claims will only be honored if OEM spare and replacement parts are used.

These operating instructions are not a supplement to our terms and conditions of sale and delivery.

### 1.3 Intended purpose

The ThermoGrip® induction device ISG4410WK-HL is used for the thermal engagement and disengagement of tools in shrink chucks.

Any other use above and beyond this is deemed not in accordance with the intended use. We will not be liable for any resulting damage. The operator bears the full risk.

Intended use also includes observing the operating instructions and compliance with the stipulated inspection and servicing intervals.

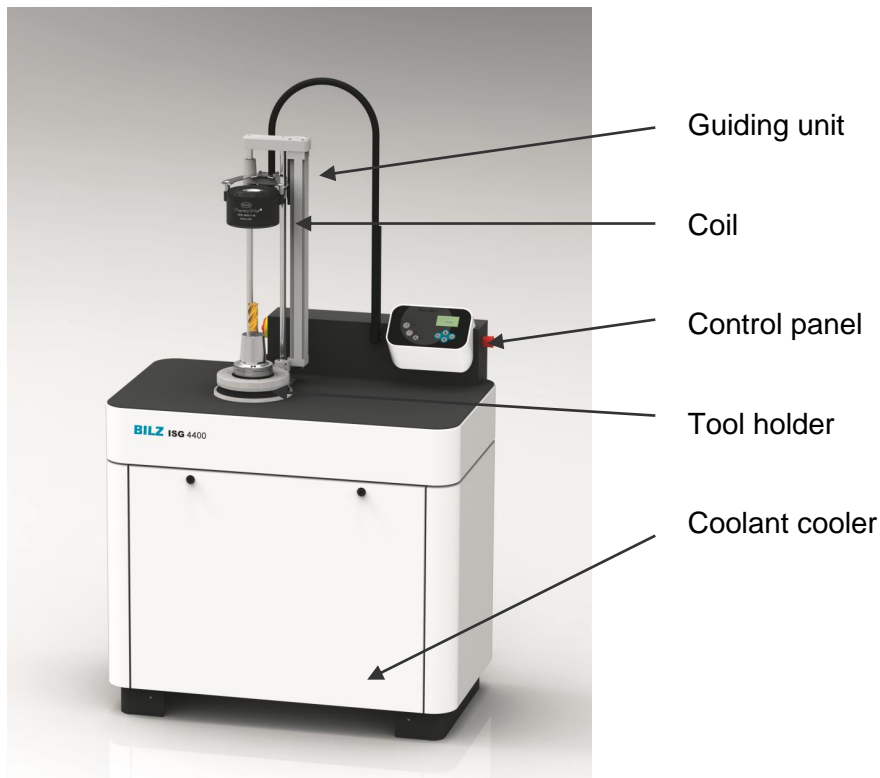

**Fig. 1**  
ThermoGrip® Induction unit ISG4410WK-HL

## 1.4 Service

We will be happy to help solve problems or perform repairs and modifications that are not described in these operating instructions. For problems or queries, make note of the device and generator serial numbers. The device serial number can be found on the type plate on the left side panel, the generator serial numbers is on the right side of the black generator box.

## 1.5 Symbols and Pictograms

**Warnings** are marked by warning triangles with hazard symbols to warn about risks that could result in damage to property or personal injury.



**Warning! Potentially fatal risk or risk of serious injury!**  
**Non-observance may lead to death or serious injury!**



**Caution! Risk of minor injury!**  
**Non-observance may lead to minor injury!**

**Information!** Information about how to carry out an action effectively and to avoid damage.

**Instructions** are marked by circles with hazard symbols or triangles with instruction specifying that an action needs to be carried out or that specific items need to be used.



**Goggles Risk of damage to the eyes!**  
**Wear goggles! During the heating phase it is possible that parts of the heated metal surfaces split off and cause injuries!**



**Gloves Risk of injury!**  
**Sharp edges or metal chips adhered to the tool can cause injury; therefore protective gloves must be worn!**

**Activities** are marked by the symbol ➤ and state the action that needs to be carried out. The result of the activity may be stated beneath the symbol for clarification purposes.

Example:

- Lower coil
- Start shrinking process
- Remove tool

## 2 Safety

The induction generator has been built to comply with the state-of-the-art design at the time of delivery and is safe to operate. Nevertheless, there are still risks involved with operating the device if it is used by untrained or unqualified personnel or if it is not used as intended. Therefore, must be observed:

**Please read the operating instructions carefully and familiarize yourself with the operating elements before commissioning and using the device!**

The operating instructions are an integral part of the function of the induction generator and must be easily accessible, legible and available in full to all persons who work with the system.

The device may only be operated by trained and competent personnel!

The device may only be used for its intended purpose and only when it is in a fully functional state!

The induction generator is designed and suited for ThermoGrip® chucks. Problems may arise when unshrinking/ shrink-fitting other chuck types leading to damage to the chucks or to the induction device itself.

All unauthorized modifications will immediately expire the manufacturer's warranty. The operator bears the sole risk of injury to the user or third parties and for any damage to the induction generator or other elements of the device!

### 2.1 Selection of the installation site

The ISG4410WK-HL is designed as a stand-alone device and must be positioned safely in a dry and clean place which is not exposed to vibrations.

Protect against dust, dirt and splash water!

Avoid direct sunlight to improve the legibility of the control panel.

### 2.2 Risks relating to electrical energy

The device has live parts inside which are dangerous if touched.

Please observe the following safety points:

- The device must not be operated when the housing is open!
- The device must only be opened by our service personnel or under strict manufacturer's guidance!
- Keep the device clean. Clean regularly!
- Never use compressed air to clean the machine or chucks nearby the machine, to prevent chips from being forced to electronics circuits



## 2.3 Risks from hot parts

The very effective heating function only heats the relevant surface zones of the chuck with the lowest heat input possible. The surface of the heated chucks reaches temperatures of up to 400°C. The coil and the cutting tool hardly heats up at all when operated properly.



**Caution! Risk of injury caused by burns from hot parts!**



As a result of the shrinking process the heated tool assembly radiates heat. Therefore, the heated chuck must be cooled in a timely manner to avoid risk of injury and damage to the coil!

Do not interrupt the automatic cooling of the shrink chuck following the shrinking process!



**Ensure that only shrink-fit chucks are used. There is a risk of injury if other chucks, especially hydraulic clamping chucks, are heated up!**

For your own safety, follow the safety instructions below when working with the device:

- The device may not be operated in an explosive environment!
- Do not use easily ignitable, solvent-based, or corrosive cleaning agents!
- Ensure that hot parts cannot be touched accidentally!
- Always wear the gloves supplied when unshrinking/ shrink fitting the tools to protect your hands from burns and cuts!
- Place hot tools on non-flammable, heat-resistant surfaces!
- Apart from the chuck and the tool, do not allow any metal objects inside the induction coil as these will also become hot!
- Never reach into the heating area of the coil during operation as rings or chains can also heat up very quickly!
- Always wear protective eyewear during shrinking! Bits of the tools or chucks can break off during the heating process and cause injuries!

## 2.4 Protecting the chuck against overheating

If the shrinking process is too long or if the chuck is reheated several times within a short period without correct cooling, the chuck and tool may overheat. Therefore, always keep the heating times as short as possible during shrink fitting.

Avoid overheating the chuck or repetitive cycles without correct cooling times!

Never re-heat a chuck that has not cooled down to room temperature.

## 2.5 Risks relating to electromagnetic radiation

If used correctly, the device does not emit any electromagnetic radiation that is dangerous to its environment. The radiation safety of the system is checked and verified through tests performed in accordance with EC Machinery Directive (see 10.6 EC Declaration of Conformity, page 57).



**The shrinking process must not be operated without the ferrite disc being inserted!**

If the induction heating is started when there is no ferrite disc being inserted in the coil, the magnetic field also affects the area close to the coil.



**The shrinking process must not be operated without chuck being inserted!**

If the induction heating is started when there is no chuck in the coil, the magnetic field also affects the area close to the coil.



**Warning!**  
**Potentially fatal risk for people with pacemakers!**



If you have a pacemaker, keep at least 3 m away from the device until you have checked with the manufacturer or your doctor that the pacemaker is not affected by the induction field.

## 2.6 Special risks

### Risk of crushing and cuts in the coil's range of motion!



Ensure that no parts of your body or objects are in the range of motion of the coil whilst the induction device is operating. The weight of the coil can cause crushing injuries and cuts in connection with the cutting tools.

### Damage of the coil and/ or the electric installment

By using Non-ThermoGrip® or too large shrink chucks, the hot chuck may touch the coil and destroy the isolation. In case of any damage of the coil and/ or the electric installment, the device has to be stopped immediately and the manufacturer has to be contacted.



**Do not operate the machine with a damaged coil, high voltage is present inside.**

### 3 Controls and commissioning ISG4410WK-HL

#### 3.1 Assembly



**Caution:**

Please inspect the unit for shipping damages prior to assembly.  
Ensure that the unit is not damaged during the unpacking process.

In particular, the cable system must not be bent or twisted out of its position of movement! Handle the unit with care.

Comply with the order of assembly!

#### 3.2 Setting up the ISG4410WK-HL

Choose a suitable place for the ISG4410WK-HL  
(see 10.2 Technical data, Environmental conditions, page 49).

The ISG4410WK-HL possesses three non-height adjustable feet and one height adjustable foot (see Fig. 2).

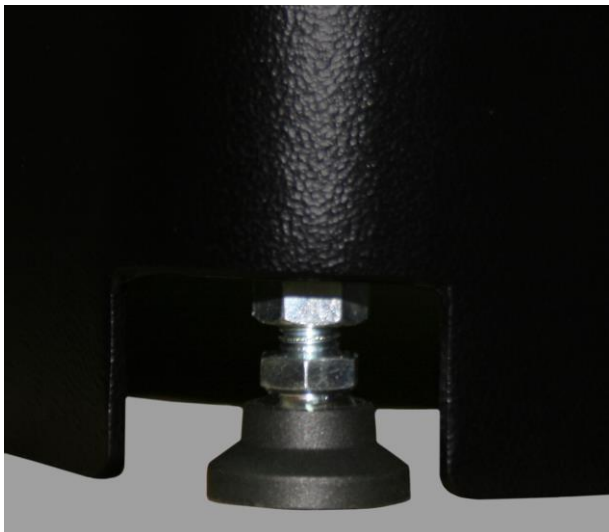

Twist up or down the height adjustable foot so that the ISG4410WK-HL stands firm and tighten with the counter nut.

**Fig. 2**  
Height adjustable foot

### 3.2.1 Mounting the non-swiveling guide unit

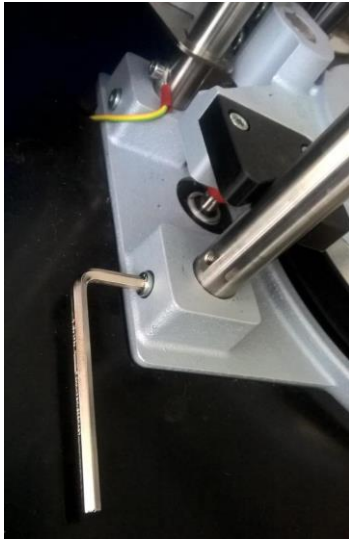

Place the guide unit sub-assembly in the bores and fasten with the two enclosed screws (DIN912 M6x20, see Fig. 3).



The PE screw at the side must be fastened tightly. (Fig. 4)

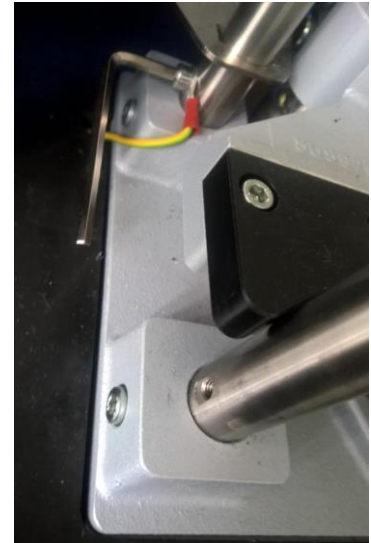

**Fig. 3**  
Inserting the guide unit in the machine

**Fig. 4**  
Fastening of the PE screws

### 3.2.2 Mounting the swiveling guide unit

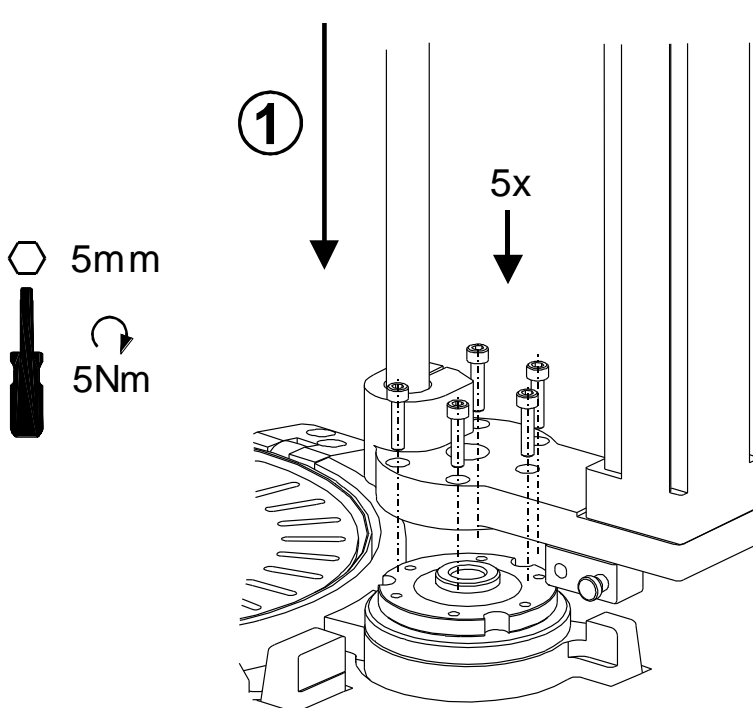

①

Mount the pre-assembled coil lift onto the swivel flange and fasten with the enclosed screws (DIN912 M6x25).

**Attention!** Please ensure that the unit is moving freely between both stops.

**Fig. 5**  
Assembly of coil lift

### 3.2.3 Mounting the connector unit

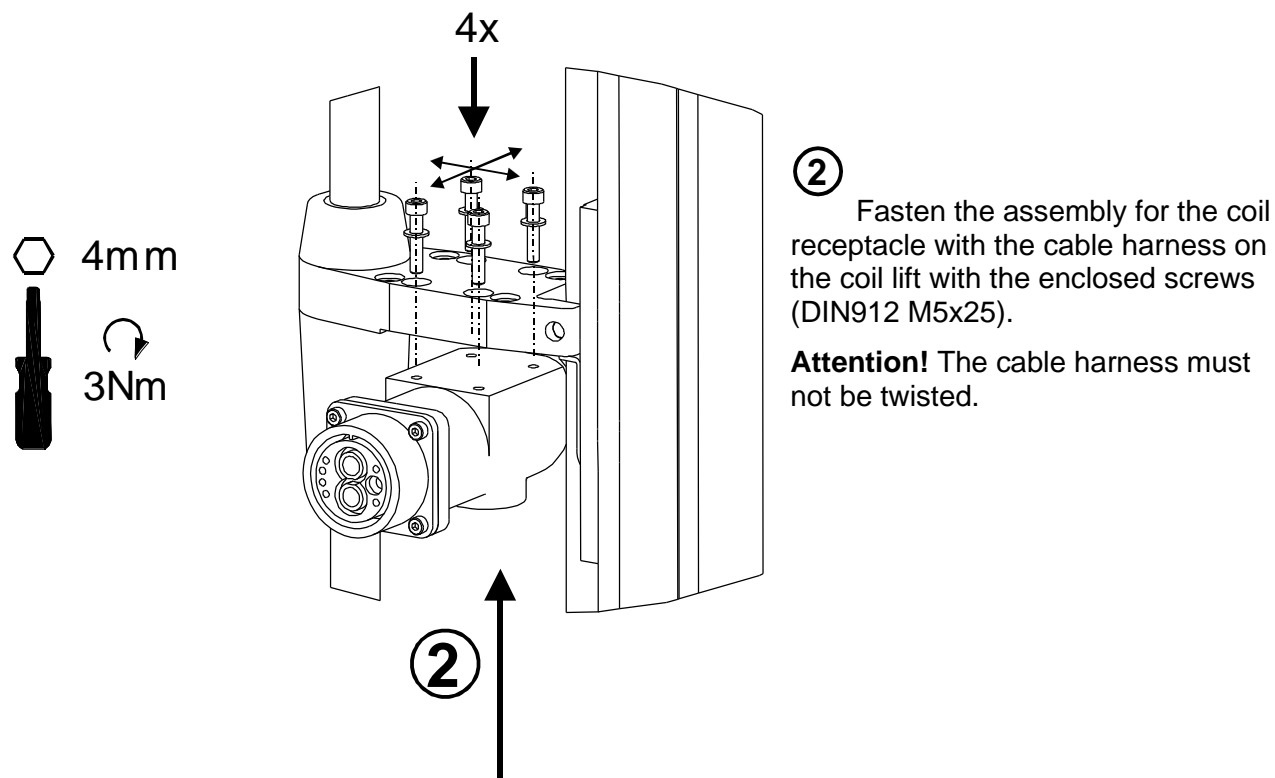

**Fig. 6**  
Fastening of the coil receptacle

### 3.2.4 Mounting the support bracket and aligning the associated coil

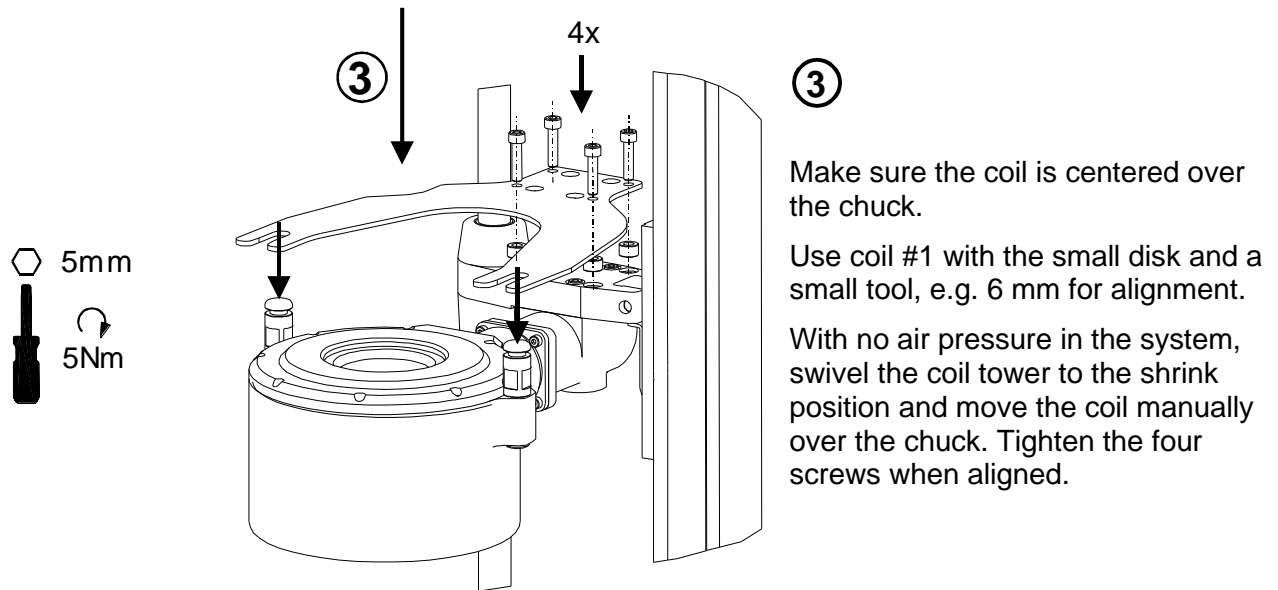

**Fig. 7**  
Fastening the support bracket

After the coil receptacle is aligned, fasten the support bracket for the larger coils with the enclosed screws (DIN912 M6x25) and spacers. Plug in a large coil and tighten the screws.



**Attention!**

**At coil change, the coil must slide without effort along the guiding slots.**

### 3.3 Connecting the guide unit



Here, the compressed air feed pipe and the return pipe have to be connected to the cylinder of the guide unit.

Both connections are on the rear side.

Take special care of the marked direction of rotation (Left/ Right) (see Fig. 8).

**Fig. 8**  
Connecting the compressed air hoses to the guide unit

### 3.4 Connecting the compressed air supply



**Compressed air must be oil-free!**

The compressed air supply must be connected properly to the unit.

The pneumatic connection of the ISG4410WK-HL is located on the left hand side.

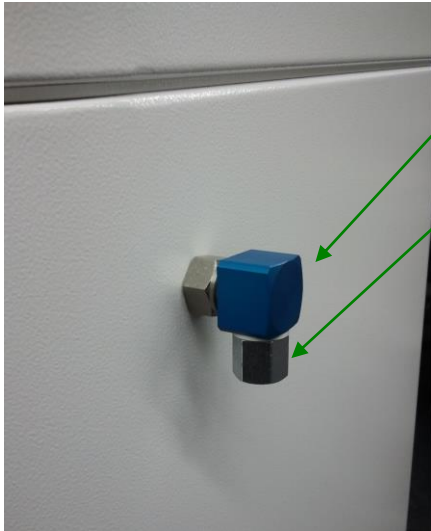

Fig. 9 shows

a rectangular adaptor G3/8 to 3/8 inch inside screw  
and

a threaded adaptor G3/8 to 3/8 NPT as option.

**Fig. 9**

Pneumatics connection ISG4410WK-HL







### 3.5 Power supply of ISG4410WK-HL

- Setting up the power supply
- For the 400V model, this is done by a pre-assembled (CEE-CEKON) plug-in connector. Just plug it into your wall outlet or transformer.
- For the 480V model, we recommend to connect it to a fused disconnect, with J-type fuses installed.  
See Chapter 10.5, Mains Connections, page 56

## 4 Operating the ISG4410WK-HL

### 4.1 Operating buttons

All the work and adjustment processes are carried out at the operator panel using 7 keys:

Button	Button name in text	Function
 START	<b>Start</b>	Start the inductive heating of the shrink-fit chuck
 STOP	<b>Stop</b>	Stop the inductive heating of the shrink-fit chuck Acknowledge error messages Interruption of <b>Start Delay</b> or <b>Stop Delay</b> Manual up/ down of the coil (press for at least 1 sec)
 COOL	<b>Cool</b>	Start manual cooling process
 	<b>up ▲</b> <b>▼ down</b>	Select various menu items Change values and settings
	<b>OK</b>	Confirm to the selection or the setting
	<b>ESC</b>	Return into the preceding menu

### 4.2 Display

All the possible selections, menus and messages for the operator are shown on the display as symbols.

The individual menus contain points of selection or input fields. A further menu is branched through moving the selection points with the arrow buttons **up ▲** and **▼ down** and by confirming with **OK**.

If an input box is skipped in a menu, then a leap is made to the last input value. The values are modified using the **up ▲** and **▼ down** buttons and confirmed by pressing **OK**.

You can always skip to the preceding menu using **ESC**.



### 4.3 Switching on the device

- Switch on the main switch

The display shows the type of the machine. Now you are in the main menu.



After selecting **Shrinking** or **Service** and pressing the **OK** button, the compressed air is switched on.



**The linear unit moves down initially and then upwards. If no coil is fitted, the carriage quickly moves upward due to the lack of weight!**

The ISG4410WK-HL is at home position and ready for use now.

### 4.4 Switching off the device

In order to avoid damage, the unit must not be switched off when the coil is raised. The unit must be switched off as follows:

- Remove the chuck from the location
- Lower the coil by continuous pressing of the **Stop** button
- Switch off at the main switch

## 5 Shrinking

### 5.1 Basic shrink-fitting information

Only tools with a ground shank and tolerance h4, h5 or h6 should be used. Tools with shank tolerance h7 cannot be securely clamped.

The following shank tolerances are required for the various shank diameters:

Shank Ø	Shank Tolerance	Type of Tool
3mm	h4	HM
4mm	h4	HM
5mm	h5	HM
≥ 6mm	h6	HM und HSS

The device uses different coils depending on the size of the tool to be shrunk-fit. For further information, see Chapter 5.4, Change the coil, page 21.

If a wrong coil and ferrite disc are used, the ferrite disc can cause damage to the tool cutting edge. The diameter of the ferrite disc bore is 2.5mm larger than the largest tool diameter that the disk is designed for. In the case of ThermoGrip® clamping chucks, the ferrite disc lies on the end face of the chuck which ensures that the coil is correctly positioned in relation to the chuck, even for extended clamping chucks. With extremely slender shapes, it may not be possible to position the coil above the clamping chuck end surface with the ferrite disc. In this case, you require the coil limit stop ISGF3414, available as an optional accessory (see options Coil limit stop, page 52).



**After the heating cycle, the shrink-fit chuck in the ISG4410WK-HL must not be touched by the operator until it has completely cooled down using the integrated direct coolant cooling.**

If it is necessary to handle the hot shrink-fit chuck for special processes, this must only be carried out using protective gloves. Shrinking chucks should only be touched with gloves and only at the collar and not in the heated area. The maximum touching time should not exceed 5 sec. even when using a protection glove.

Ensure that the chucks stand straight and are secure in the tool holders. Even though the shrinking of tools with Weldon, Whistle notch or similar shanks with non closed cylinder geometry is possible, cylindrical shanks such as DIN1835 Form A are preferred, as these enable a greater holding force and the smallest amount of imbalance.



**Please ensure that the tool shanks used are not damaged in the clamping area.**

To achieve the best possible clamping forces only insert clean, grease-free shafts in the chuck. Ensure that there are no cutting flutes in the clamping area when deciding on the clamping depth.

## 5.2 Work sequences when clamping, releasing or changing a tool

For your own safety, please observe the following rules when working with the ISG4410WK-HL:



**Always observe the safety instructions for all shrink-fit processes!**

The cooling can be operated manually at any time through pressing the **Cool** button.



**Use safety gloves!**

Shrinking chucks should only be handled with gloves and only at the collar and not in the heated area. The maximum contact time should not exceed 5 sec. even when using a protective glove.



**Wear safety goggles!**

### 5.2.1 General advices

Select the respective tool holder for the chuck and place this on the footprint.  
(see Chapter 10.3.1, Available additions and optional accessories, page 51)

Insert the chuck into the tool holder. In the case of short tools to be gripped and ThermoGrip® clamping chucks, you can insert the tools 5 mm deep into the front part of the clamping chucks.

When the shrinking menu is selected you get an overview of all shrinking functions.

## 5.2.2 Clamping

By pressing on the tool during the subsequent heating phase you assist the clamping process.

If the tool has been inserted and the shrinking time has not yet ended, it is helpful to end the heating process with the **Stop** button, so as not to continue to heat the tool unnecessarily. After the selected shrinking time runs out or the **Stop** button is pushed, the coil is moved to the upper end position and the cooling device is driven upwards.

Afterwards the chuck can be removed by the operator.

## 5.2.3 Releasing

By pulling on the tool during the subsequent heating phase you assist the releasing process.



**Place the removed tool on a heat resistant surface and protect people from accidentally touching the tool and the hot clamping chuck.**

If the tool has been released and the shrinking time has not yet ended, it is helpful to end the heating process with the **Stop** button, so as not to continue to heat the tool unnecessarily. After the selected shrinking time runs out or the **Stop** button is pushed, the coil is moved to the upper end position and the cooling device is driven upwards.

Afterwards the chuck can be removed by the operator.

## 5.3 Change the ferrite disc

Ensure that there is no chuck beneath the coil.

Press the **Stop** button for approx. 1 sec. The linear unit moves into the lower position and it is easier to change the disc.

Press the clamping ring together and remove it from the coil. After that you can take the ferrite disc from the coil.

Select the correct ferrite disc suited to the correct shank-Ø into the coil.  
See also Chapter 5.5.1.1, Table of factory defined parameters, page 25.

After that fix the ferrite disc on the top of the coil housing with the clamping ring.

Press the **Stop** button again for approx. 1 sec and the linear unit moves back upwards.

## 5.4 Change the coil

Ensure that there is no chuck beneath the coil.

Press the **Stop** button for approx. 1 sec. The linear unit moves into the lower position and it is easier to change the disc.

### 5.4.1 Dismantle the coil

To do this, twist the union nut on the bayonet fixing through approx. 90° counterclockwise direction and at the same time pull the coil horizontally forwards.

The linear unit moves back to the start position by pressing the **Stop** button for approx. 1 sec.

### 5.4.2 Fitting the coil

When inserting the coil ensure that the lettering on the coil is on the correct side and is horizontal. Insert the coil straight and thread on the union nut. Turn the union nut through approx. 90° in a clockwise direction until you feel it locking into place.

The bayonet fixing plug-in connector is correctly fastened when the red control points of the union nut are inline with the coil and the counterpart on the linear unit.

Check the coil for correct installation and a firm fit.

Ensure the coil slides without effort along the guiding slots.

The linear unit moves back to the start position by pressing the **Stop** button for approx. 1 sec.



**Ensure that you protect the connector mechanism of coils not being used from soiling.**



**Never leave the device for a lengthy period without a connected coil, to prevent soiling of the devices, plug-in all connectors too.**

**5.5 Shrink-fit operating modes**

Parameter

Manual

Tool memory

Favorites

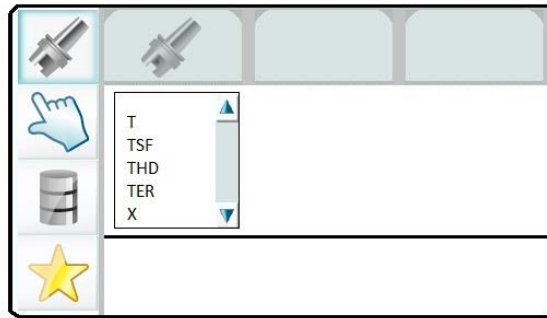

PARAMETER	MANUAL	TOOL MEMORY	FAVORITES
<p>..., if you use a ThermoGrip® chuck. The parameters shrinking time and shrinking output power are programmed for the ThermoGrip®-chuck.</p>	<p>..., if you use another chuck or tool and want to adjust the shrinking parameters yourself.</p>	<p>..., if you use chuck of your own with shrinking parameters of yourself.</p>	<p>..., if you use a table of the most shrunk tools.</p>

Select with **up ▲** and **down ▼** the desired function and activate with **OK**.

### 5.5.1 ThermoGrip® clamping chucks: PARAMETER

The necessary parameters for the ThermoGrip® chuck such as the generator output power, heating period, cooling time, coil and disc sizes for the chuck type are programmed in the factory equipment of the ISG4410WK-HL (see 5.5.1.1 Table of factory defined parameters, page 25).

Unless otherwise specified, use standard coil #1 (ISGS3400-1-HL, page 50).



**Attention: Special ferrite discs for TSF and TER shrink-fit chucks are necessary (see Ferrite discs TSF and TER, page 53).**



**Attention: For TSF and TER shrink-fit chucks only shrink in carbide tools!**

#### Step 1: Select chuck type

Select with **up ▲** and **▼ down** the desired chuck type

Activate with **OK**.

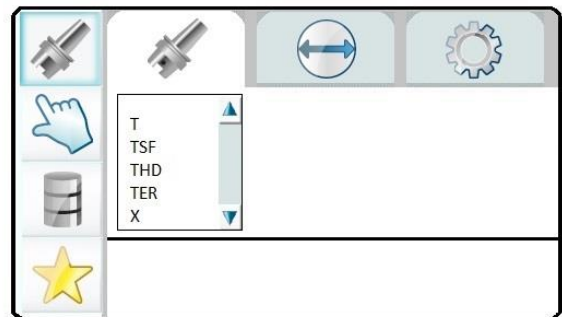

#### Step 2: Select diameter

Select with **up ▲** and **▼ down** the according diameter

Activate with **OK**.

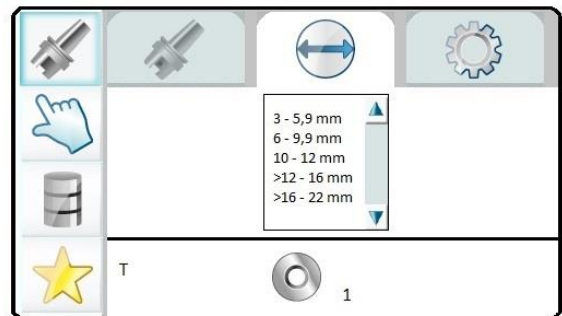

The status (bottom line) shows type of the chuck, the assigned ferrite disc and, if necessary, the assigned coil.

## Shrinking

### Step 3: Additional options

Select with **up ▲** and **down ▼** additional options and activate or deactivate with **OK**.

The status (bottom line) shows the type of chuck and the assigned shrinking time and output power.

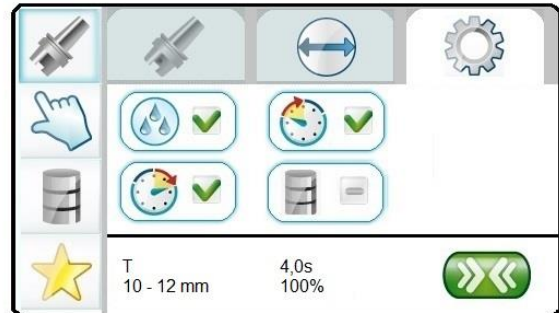

The blinking symbol  shows the device is ready for shrinking

Following options are possible:



Deselecting the automatic cooling, This option is always set active after every shrinking. Other options see Chapter 6.2 Setting up and configuration of cooling time, page 36



**Start Delay** Delay of the beginning of the shrinking.  
See Chapter 6.3, Enter Start Delay, page 38



**Stop Delay** (Dwell time) Delay of the beginning of the cooling process.  
See Chapter 6.4, Enter Stop Delay, page 38



Setup parameters for TOOL MEMORY.  
See Chapter 5.5.3.1, Setup TOOL MEMORY at the machine, page 32

### Step 4: Start shrinking

- Start shrinking with **Start**
- The water cooling is checked before the heating up of the chuck
- The coil moves down automatically
- The operation steps are shown on the display by a progress bar



### 5.5.1.1 Table of factory defined parameters

T- chucks (Standard Type according to DIN69882-8)

Designation of chuck Txxxx

Ø-range in mm	Ø-range in inches	Ferrite disc	Shrinking time in sec	Shrinking output power in %
3 – 5,9	1/8 – 3/16	ISGS3201-0	4,0	60
6 – 9,9	1/4 – 5/16	ISGS3201-1	4,0	95
10 – 12	3/8	ISGS3201-1	4,0	100
> 12 – 16	1/2 – 5/8	ISGS3201-2	4,0	100
> 16 – 22	3/4	ISGS3201-2	4,0	95
> 22 – 25	1	ISGS3201-3	7,0	100
> 25 – 32	> 1 – 1.1/4	ISGS3201-3	8,2	100

TSF- chucks (Slender design)

Designation of chuck TSFxxxx

Ø in mm	Ø in inches	Ferrite disc	Shrinking time in sec	Shrinking output power in %
3	1/8	ISGS3201-TSF03	3,0	25
4	5/32	ISGS3201-TSF04	3,0	25
5	3/16	ISGS3201-TSF05	3,0	28
6	1/4	ISGS3201-TSF06	3,0	38
8	5/16	ISGS3201-TSF08	3,0	43
10	3/8	ISGS3201-TSF10	3,0	53
12	1/2	ISGS3201-TSF12	4,0	43
14	9/16	ISGS3201-TSF14	3,0	47
16	5/8	ISGS3201-TSF16	3,0	68
18	11/16	ISGS3201-TSF18	3,0	68
20	3/4	ISGS3201-TSF20	3,0	63
25	1	ISGS3201-TSF25	4,0	84

THD- chucks (Enforced design)

Designation of chuck THDxxxx

Coil	Designation	Ø in mm	Ø in inches	Shrinking time in sec	Shrinking output power in %
2	ISGS3400-2-HL	16	5/8	20	100
2	ISGS3400-2-HL	20	3/4	19	100
2	ISGS3400-2-HL	25	1	28	100
5	ISGS3400-5-HL	32	1.1/4	29	100
5	ISGS3400-5-HL	40	1.1/2	39	100
5	ISGS3400-5-HL	50	2	40	100

## TER Shrink collets, geometry according ER 11

Designation	Ferrite disc	∅ in mm	∅ in inches	Time in sec	Power in %	Dwell time in sec
TER0300/11	ISGS3201-TER11-1	3	1/8	3,5	25	3
TER0400/11	ISGS3201-TER11-1	4	5/32	3,5	25	3
TER0600/11	ISGS3201-TER11-1	6	1/4	2,5	30	0

## TER Shrink collets, geometry according ER 16

Designation	Ferrite disc	∅ in mm	∅ in inches	Time in sec	Power in %	Dwell time in sec
TER0300/16	ISGS3201-TER16-1	3	1/8	3,7	32	3
TER0400/16	ISGS3201-TER16-1	4	5/32	2,7	28	3
TER0600/16	ISGS3201-TER16-2	6	1/4	3,0	34	0
TER0800/16	ISGS3201-TER16-2	8	5/16	3,0	45	0
TER1000/16	ISGS3201-TER16-2	10	3/8	3,0	45	0

## TER Shrink collets, geometry according ER 20

Designation	Ferrite disc	∅ in mm	∅ in inches	Time in sec	Power in %	Dwell time in sec
TER0300/20	ISGS3201-TER20-1	3	1/8	3,7	36	3
TER0400/20	ISGS3201-TER20-1	4	5/32	3,2	36	3
TER0600/20	ISGS3201-TER20-1	6	1/4	2,7	45	0
TER0800/20	ISGS3201-TER20-1	8	5/16	3,0	45	0
TER1000/20	ISGS3201-TER20-1	10	3/8	4,0	45	0
TER1200/20	ISGS3201-TER20-1	12	1/2	4,0	45	0

## TER Shrink collets, geometry according ER 25

Designation	Ferrite disc	∅ in mm	∅ in inches	Time in sec	Power in %	Dwell time in sec
TER0300/25	ISGS3201-TER25-1	3	1/8	6,0	54	3
TER0400/25	ISGS3201-TER25-1	4	5/32	4,7	54	3
TER0600/25	ISGS3201-TER25-2	6	1/4	3,0	50	0
TER0800/25	ISGS3201-TER25-2	8	5/16	2,7	50	0
TER1000/25	ISGS3201-TER25-2	10	3/8	4,7	51	0
TER1200/25	ISGS3201-TER25-3	12	1/2	5,7	50	6
TER1400/25	ISGS3201-TER25-3	14	9/16	3,7	50	0
TER1600/25	ISGS3201-TER25-3	16	5/8	3,7	45	6

## TER Shrink collets, geometry according ER 32

Designation	Ferrite disc	∅ in mm	∅ in inches	Time in sec	Power in %	Dwell time in sec
TER0600/32	ISGS3201-TER32-1	6	1/4	2,7	75	0
TER0800/32	ISGS3201-TER32-1	8	5/16	2,7	75	3
TER1000/32	ISGS3201-TER32-2	10	3/8	3,7	70	0
TER1200/32	ISGS3201-TER32-2	12	1/2	4,7	65	0
TER1400/32	ISGS3201-TER32-2	14	9/16	3,7	70	0
TER1600/32	ISGS3201-TER32-2	16	5/8	5,7	70	0
TER1800/32	ISGS3201-TER32-2	18	11/16	5,7	70	3
TER2000/32	ISGS3201-TER32-2	20	3/4	5,7	65	3

# Shrinking

## 5.5.2 Shrinking with free "Parameter" selection: MANUAL

This mode is intended for shrinking special tools or special clamping chucks, which only occur in seldom cases. Furthermore, this mode can be used to set the shrinking parameters for frequently used special chucks or tools.

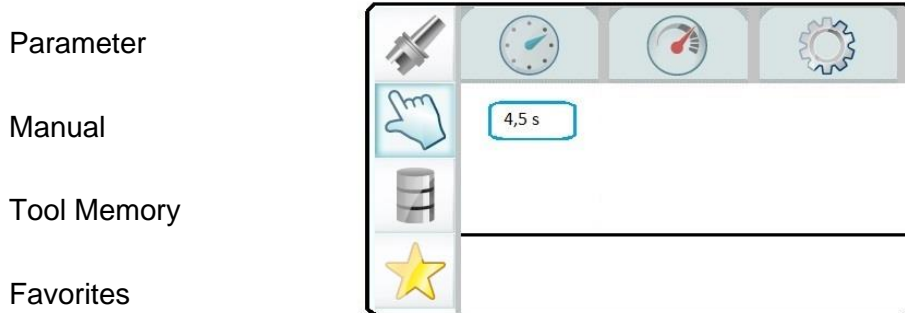

Select with **up ▲** and **▼ down** the function "MANUAL" and activate with **OK**.

### Step 1: Select shrinking time

Select with **up ▲** and **▼ down** the desired shrinking time in steps of 0,5 s (0 – 60 s)  
Activate with **OK**.

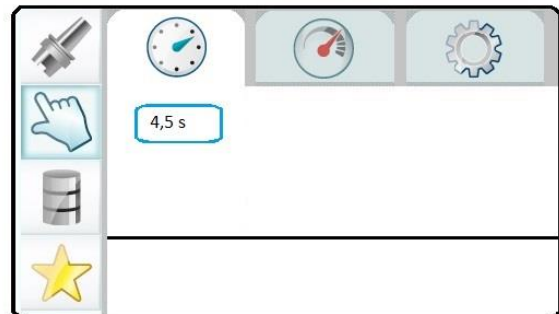

### Step 2: Select shrinking output power

Select with **up ▲** and **▼ down** the desired output power in steps of 5% (5% – 120%)  
Activate with **OK**.

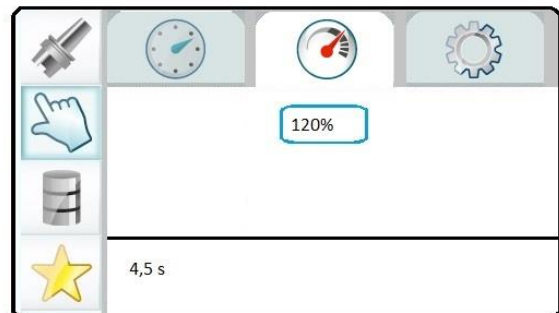

### Step 3: Additional options

Select with **up ▲** and **▼ down** additional options and activate or deactivate with **OK**.

The status (bottom line) shows the selected shrinking time and output power.



The blinking symbol shows the device is ready for shrinking

Following options are possible:



Deselecting the automatic cooling, This option is always set active after every shrinking. Other options see Chapter 6.2 Setting up and configuration of cooling time, page 36



**Start Delay** Delay of the beginning of the shrinking.  
See Chapter 6.3, Enter Start Delay, page 38



**Stop Delay** (Dwell time) Delay of the beginning of the cooling process.  
See Chapter 6.4, Enter Stop Delay, page 38



Inverse Shrinking.  
See Chapter 5.5.2.1, Special shrinking: Inverse shrinking (shrinking from the bottom), page 30

## Step 4: Start shrinking

- Start shrinking with **Start**
- The water cooling is checked before the heating up of the chuck.
- The coil moves down automatically.
- The operation steps are shown on the display by a progress bar

By delivery of the ISG4410WK-HL the manual shrinking procedure is enabled. The manual shrinking process can be disabled in the configuration menu.  
See Chapter 6.8, Lock shrinking operation, page 40.

There is also a possibility to carry out the shrinking process using the **Start** button when the heating time = 0 seconds is selected. The chuck is heated with the set output power for as long as you press and hold this button.

The shrinking process is ended after releasing the **Start** button and the cooling process can be started.

If the heating energy selected (time x output power) is too high, the shrink-fit chuck and/ or the tool can easily overheat. In serious cases, permanent damage can occur to the chucks and tools. Please therefore ensure the following is observed:



**If the suitable parameter is not known, begin with small values for the time and output power and increase them until the clamping and releasing functions work perfectly!**

- Especially for smaller tools, do **NOT** increase the heating time by one second at the same power setting. Instead, increase it by 1s and reduce the output power by 20% at the same time. The product of power x time is the energy input. If a cycle at 3s and 100% ( $3 \times 1 = 3$ ) is not successful, increase to 4s/ 80% ( $4 \times 0.8 = 3.2$ ) and so forth.
- Allow the chuck and tool to cool to room temperature before any new heating cycle is started! Ensure that the coil is suitable for the chuck and the tool.
- An internal check of the coil cannot be carried out in this case. Therefore ensure that the coil is suitable for the chuck and the tool. To do this, check that the clamping area of the chuck fits in the coil, the coil ferrite disc touches the end face of the chuck (or is at least only a very short distance apart) and that the tool has sufficient clearance in the ferrite disc bore so that the cutting edge cannot be damaged! If you notice that the chuck, tool or coil heat to very hot temperatures, interrupt the process immediately using the **Stop** button and check the shrinking parameters!

Guidelines for experimentally determining the necessary shrinking parameters for special chucks and special coils

### 1) Basic settings:

	Shrinking output power in %	Shrinking time in sec
Special chucks and HSSE/ CARBIDE tool shafts with universal coil and ferrite discs (ISGS3201-0, ISGS3201-1, ISGS3201-2, ISGS3201-3)	100	2
Special chucks and CARBIDE tool shafts with a special coil	70	3

### 2) Sequence:

**Insert tool shank in the counterbore and start the shrinking process.**

- a) If the tool slides **completely** in the chuck bore:  
Use the current values of Heating time and Output Power as suitable shrinking parameters.
- b) If the tool does **not** slide into the chuck bore:  
Increase the shrinking time T in steps of 1s and then repeat the shrinking process until the tool shaft completely slides into the chuck bore. It is important to ensure that the shrink-fit chuck is cooled down to room temperature before each further shrinking attempt.  
Then accept the last selected shrinking parameters Heating time and Output Power.
- c) The tool shaft only slides **partially** in to the shrinking chuck bore and is thus not correctly gripped during cooling process.  
Allow the chuck to completely cool down to room temperature and increase the shrinking time T in steps of 1s, shrink and try to pull out the tool. Repeat this step until the tool can be easily removed from the heated chuck. It is important to ensure that the shrink-fit chuck is cooled down to room temperature before each further heating cycle is started.  
Once successful, accept the last selected parameters for Heating time and Output Power and store them to memory.

### 5.5.2.1 Special shrinking: Inverse shrinking (shrinking from the bottom)

ISG4410 enables the shrinking of tools inversely where the cutting edge diameter is larger than the coil diameter and would therefore not go through the coil during a conventional shrinking process.

For this purpose, it is required that you'll need a special elongated tool holder (Fig. 10), a coil limit stop (Fig. 11) and a special coil (ISGS3400-3.1-HL, page 51) without a ferrite disc.



**Fig. 10**  
Tool holder

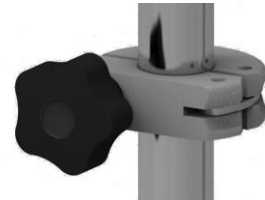

**Fig. 11**  
Coil limit stop

The operation inverse shrinking can be selected with the option **Inverse**.

### 5.5.2.2 Inverse shrinking-in

In order to shrink-in a tool, choose the option "Inverse shrinking"

The coil moves automatically to the lower end position of the cylinder. Now put the chuck into the tool holder and position it in the coil. Take care that the tool holder with the chuck is positioned in the centre of the coil.



Place the coil limit stop at the guiding rod above the coil. Push up the coil manually, until it is placed in shrinking position to the chuck. The coil is in the correct position if the ferrite disc nut is on a level with the front side of the chuck. Now position the coil limit stop so that the coil will stop at that position when going in the automatic mode.

Proceed as described under item 5.2.2 Clamping, page 20.

Take the chuck with shrunk-in tool out of the coil, when the coil has retracted.



**Put the hot chuck on a heat resistant surface and prevent people from touching the tool and the hot chuck accidentally.**

### 5.5.2.3 Inverse shrinking-out



In order to shrink-out a tool, put the chuck in the suitable tool holder with the unit switched on and the operation “Inverse shrinking” selected. (The coil is located in the lower end position of the cylinder). Proceed as described in the Chapter 5.5.2.2, Inverse shrinking-in.

Assist the detaching of the tool by pulling the tool gently.

Take the tool and the chuck out of the coil, when the coil has retracted.



**Put the tool and the chuck on a heat resistant mat and prevent people from touching the tool and the hot chuck accidentally.**

### 5.5.2.4 Inverse shrinking tool change

You have the possibility to take a clamped tool out during the heating phase and immediately replace in another tool. Firstly, shrink-out the tool, as described in the Chapter 5.5.2.3, Inverse shrinking-out, page 31. Do not interrupt the heating process with **Stop** !

A new tool may be placed in the chuck directly after having shrunk-out the old tool without waiting for the coil to go to the lower end position of the cylinder.

Put the taken out tool on a heat resistant mat and prevent people from touching the tool and the hot chuck accidentally.

Take the chuck with shrunk-in tool out of the coil, when the coil has retracted.



**Put the tool and the chuck on a heat resistant mat and prevent people from touching the tool and the hot chuck accidentally.**

### 5.5.2.5 Shrinking with coil limit stop ISGF3414

There is a possibility that with slim clamping chuck designs, special chucks, or when inverse shrinking, that the coil cannot be positioned through its cover disk. In that case you should use the coil limit stop which can be obtained as an accessory (ISGF3414, page 52).

The coil limit stop is mounted around the guiding rod and locked with the locking screw.



**Take care that the stop – when not needed – is removed and that the coil does not stop at the wrong position unintentionally.**

In order to position the coil limit stop, put a chuck in its tool holder in the shrinking position below the coil. The coil is in the correct position if the ferrite disc nut is on a level with the front side of the clamping chuck. Now position the coil limit stop so that the coil will be stopped at that position when going automatically. Lock the stop in this position with the locking screw.

### 5.5.3 Define your own Parameters: TOOL MEMORY

#### 5.5.3.1 Setup TOOL MEMORY at the machine

At the beginning, a similar standard chuck is selected from the existing parameter list.

Start with mode PARAMETER similar to standard shrinking (see Chapter 5.5.1, ThermoGrip® clamping chucks: PARAMETER, page 23).

It is important to define the coil and disc for the new chuck.

Selecting the option „memory“ will switch into manual mode.



**Manual mode must be unlocked**  
(see Chapter 6.8, Lock shrinking operations, page 40)

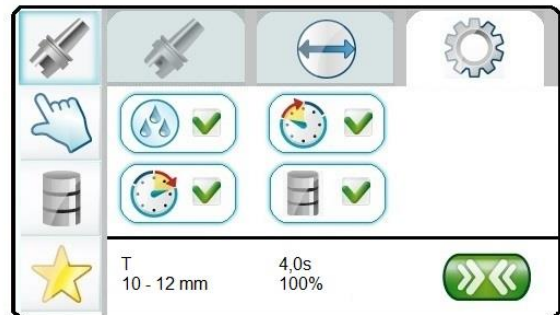

The actual parameters (shrinking time and power) are copied and can be changed now (see Chapter 5.5.2, Shrinking with free “Parameter” selection: MANUAL, page 27).

After selecting you come to the manual shrinking mode. The desired parameters may be tested by shrinking and can be adjusted again until they are perfect.

Selecting the option „memory“ will save the actual time, power and all other options. The predefined coil and disc will also be saved into a new set of parameter data.

The new set of data is named like the original tool designation heading with an additional letter “M” and a digit.



For e.g., if a chuck similar to TSF with D=8 mm is desired, the new set of data will have the designation „M1 TSF08“. A second set of data with the same chuck as origin, will have the designation „M2 TSF08“.

The function „TOOL MEMORY“ is enabled now and all sets of own defined shrinking parameters are available (see Chapter 5.5.3.3, Select your own tool parameters, page 33).

The names are fixed and can not be changed at the operating panel.

To change the name or adjust the parameter set, the tool memory has to be read out to an USB memory stick and following the parameter sets can be edited on a PC with the optional program „ToolMemoryEditor“ (see Chapter 6.9, Write the tool memory onto an USB memory stick, page 40).

To quit the manual mode without activating the option „memory“ stop the function without memorizing the new set of data.



# Shrinking

## 5.5.3.2 Setup or change your own parameters externally (option)

With the PC based program „ToolMemoryEditor“ you can define tools by yourself and read into the control with an USB memory stick.

The USB interface is located at the generator module on the right side.

Read in the generated file of tools:

- Switch off the device
- Plug in the USB stick
- Switch on the device

While starting up, the new tool data is read in. The USB stick can be removed as soon as the main menu appears (see Chapter 4.3, Switching on the device, page 17).



**NOTE! Reading back the (changed) sets of parameters will overwrite the existing tool memory.**

The function „TOOL MEMORY“ is enabled with correct tool data. These are now available.

## 5.5.3.3 Select your own tool parameters

Select with **up ▲** and **▼ down** the function "TOOL MEMORY"

Activate with **OK**.

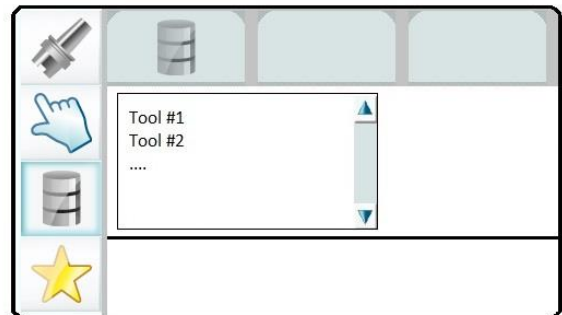

A list of the generated tools appears

Select with **up ▲** and **▼ down** the desired tool

Activate with **OK**.

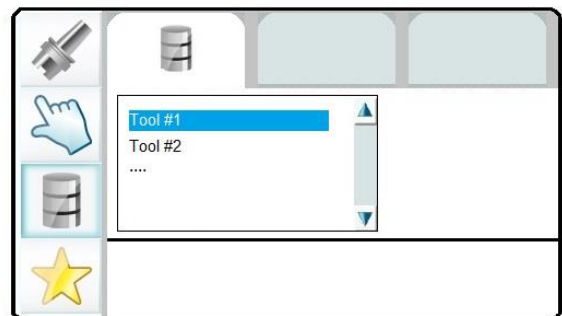

The menu shrinking will be selected immediately

Continue as described in Chapter 5.5.1, ThermoGrip® clamping chucks: PARAMETER, page 23

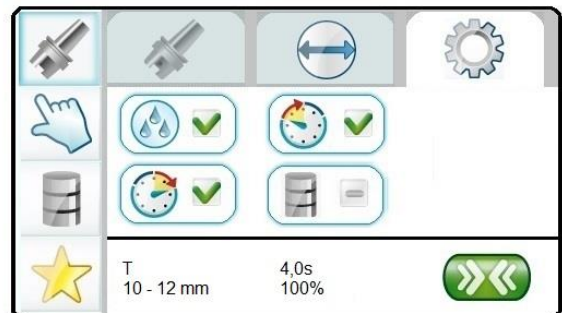

# Shrinking

## 5.5.4 List of most used tools: FAVORITES

A top-ten list of the most used tools is directly available with the function „Favorites“.

Select with **up ▲** and **▼ down**  
the function "FAVORITES"

Activate with **OK**.

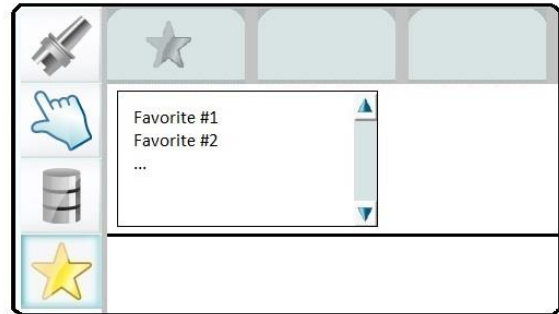

A list of the most used tools appears  
Select with **up ▲** and **▼ down** the  
desired tool

Activate with **OK**.



The menu shrinking will be selected immediately  
Continue as described in Chapter 5.5.1,  
ThermoGrip® clamping chucks: PARAMETER,  
page 23

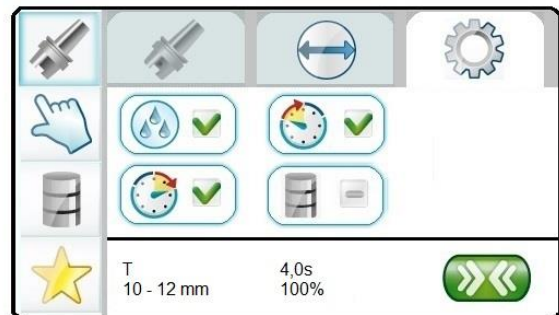

## 6 Configuration

With multiple pressings of **ESC** you come to the main menu.

**Shrinking**

**Configuration**

**Service**



Select with **up ▲** and **▼ down** the function **Configuration** and activate with **OK**.

If the **Configuration** is protected by a password you have to enter it first.

How to activate/ deactivate the password see Chapter 6.6, Password on/ off or change, page 39

You can increase or decrease the numbers with **up ▲** or **▼ down**.

Confirm with **OK** and go to the next decimal figure of the password.

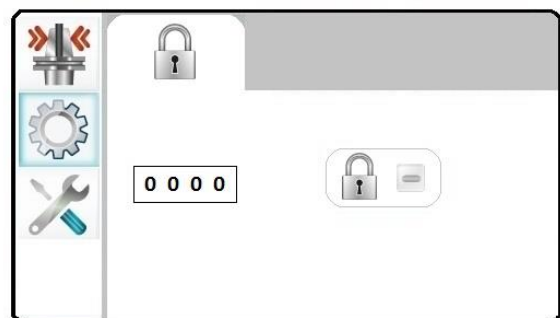

Once all 4 numbers are correct (for e.g. 3480) confirm the password with **OK**.

When a wrong password is entered you have to repeat the input.

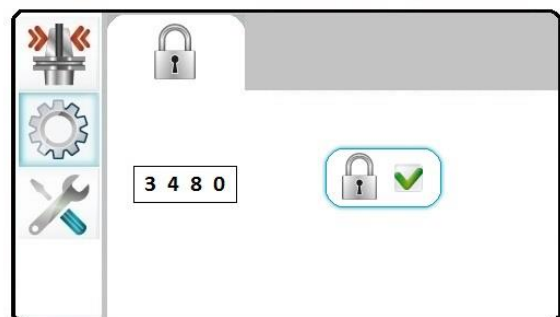

If the password is correct, the following appears in the **Configuration** display

Select the options with **up ▲** and **▼ down** and activate with **OK**.

If the symbol „Manual Shrinking“ does not appear, you first have to define a password. See Chapter 6.6, Password on/ off or change, page 39.



## Configuration

### 6.1 Switching between mm/ inch

The diameter of the tool can be shown on the display in mm or in inches.

Select the desired unit with **up ▲** and **▼ down** and confirm with **OK**.

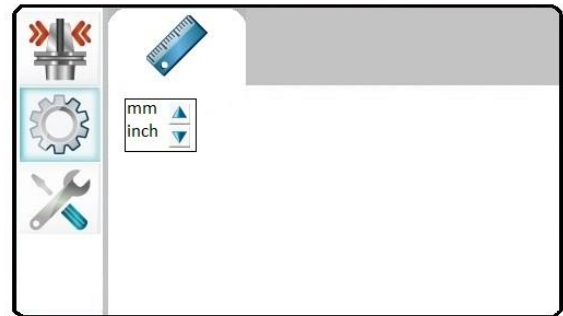

### 6.2 Setting up and configuration of cooling time

If only the symbol „cooling“ appears, you have to enter a password first.

See Chapter 6.6, Password on/ off or change, page 39.

Select the functions with **up ▲** and **▼ down** and activate with **OK**. The active function is marked with **✓** and confirmed with **OK**.



#### 6.2.1 Setting up of cooling time

The cooling time can be extended to a maximum of 200 % of the factory setting.

A cooling time less than 100 % is not possible for safety reasons.

Select the desired value with **up ▲** and **▼ down** and confirm with **OK**.

You can leave the menu without saving the value by pressing **ESC**.

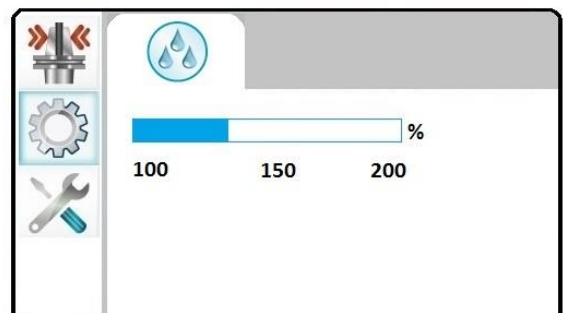

# Configuration

## 6.2.2 Configuration of cooling time

The cooling function can be configured differently for the "parameter shrinking" and / or "manual shrinking" functions.

Select the functions with **up ▲** and **▼ down** and activate with **OK**. The active function is marked with **✓** and confirmed with **OK**.

The configuration of the cooling time for parameter shrinking or manual shrinking is selected with the corresponding symbol.



### 6.2.2.1 Configuration of cooling time for "parameter shrinking"

Select the functions with **up ▲** and **▼ down**.

The active function is marked with **✓**.

Confirm the function with **OK** and leave the menu.

You can leave the menu without saving the function by pressing **ESC**.



The 3 functions possible are as follows:

- If the cooling is deselected, cooling is automatically selected again after a shrinking process (default).
- The cooling process is always active and can not be deselected by the operator.
- The cooling process is always deselected and must be started manually by the operator.

### 6.2.2.2 Configuration of cooling time for "manual shrinking"

Select the functions with **up ▲** and **▼ down**.

The active function is marked with **✓**.

Confirm the function with **OK** and leave the menu.

You can leave the menu without saving the function by pressing **ESC**.



All functions of cooling time for "manual shrinking" are similar to chapter 6.2.2.1.

## 6.3 Enter Start Delay

Around 3 seconds will pass before the generator starts. If this waiting time is too short to insert bulky tools, the **Start Delay** option can be used to set an additional delay of up to 30s.

Select the desired value with **up ▲** and **▼ down** and confirm with **OK**.

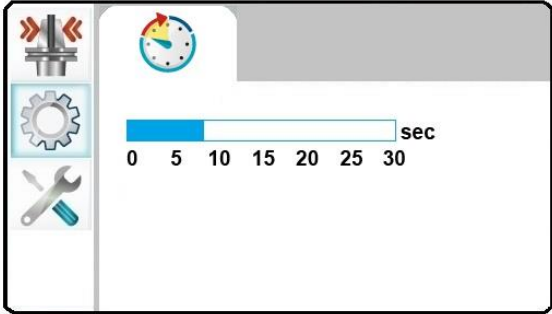

## 6.4 Enter Stop Delay

After the selected shrinking time has ended, the coil is rapidly driven upwards. If the dwell time of the coils in the lower position is not long enough, a delay time of 30 seconds can be set in the option of the **Stop Delay** that enables the safe extraction of heavy tools with shrink fitting. In this case the coil stays in the lower position until the selected time has expired or unless the **Stop** button is activated.

Select the desired value with **up ▲** and **▼ down** and confirm with **OK**.

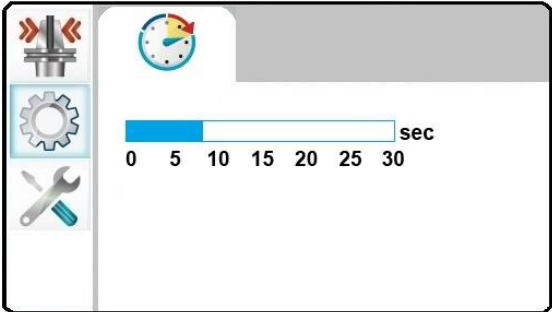

## 6.5 Read customized parameters

The function is to read customized parameters from an USB memory stick.

These parameters replace the factory defined values (see 5.5.1.1 Table of factory defined parameters, page 25).

The setup of this parameter file is only allowed by the manufacturer due to warranty reasons.

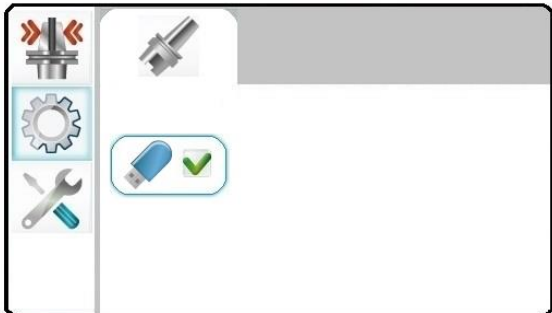

### 6.6 Password on/ off or change

Entering "0000" will switch off the password.  
This is the factory default.

Whenever you enter a value unequal to "0000" you switch on the password request.

You can enter a password of your choice with up to 4 decimal figures (for e.g.: 3480).

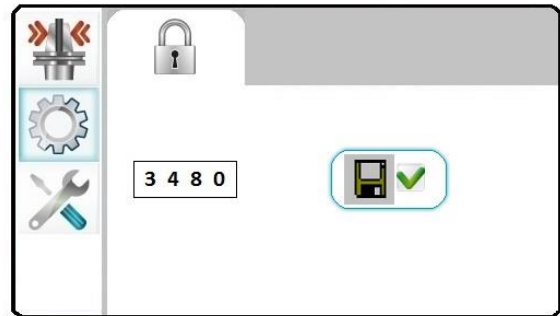

You can increase or decrease the numbers with **up ▲** or **▼ down**.

Confirm the value with **OK** and go to the next decimal figure of the password.

Pressing again **OK** will save the password.

You can leave the menu without saving the password by pressing **ESC**.

### 6.7 Reset list of favorites

The list of favorites may be cleared by activating the button with **OK**.

The new list of tools will be generated automatically according to their occurrence.

See Chapter 5.5.4, List of most used tools: FAVORITES, page 34.

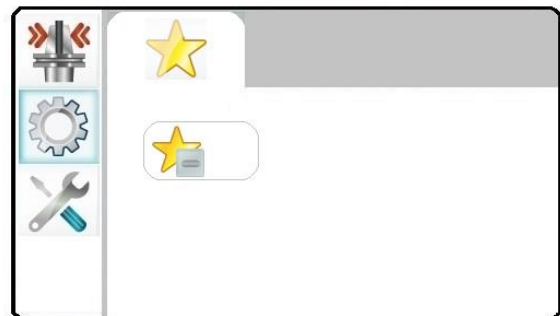

### 6.8 Lock shrinking operations

With the ISG4410, it is possible to lock the functions “Manual shrinking” and / or “Parameter shrinking” for the operator using a password. The function is only applied when ThermoGrip® shrink-fit chucks are used and any overheating occurs as a result of an operating error of the operator must be excluded.

Select or deselect with **up ▲** and **▼ down** and confirm with **OK**.

First of all a password must be assigned to be able to lock the functions (see Chapter 6.6, Password on/ off or change, page 39).

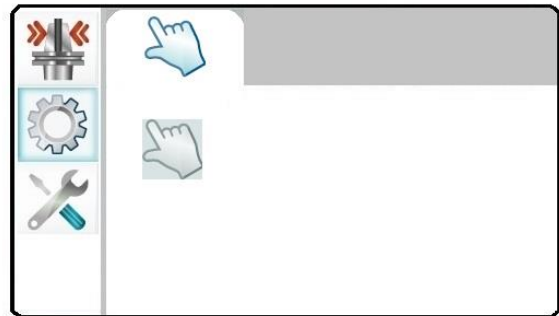

### 6.9 Write the tool memory onto an USB memory stick

Select the options with **up ▲** and **▼ down**.

Activating the USB button will write the tool memory onto the USB memory stick.

Format the USB memory stick as FAT32.

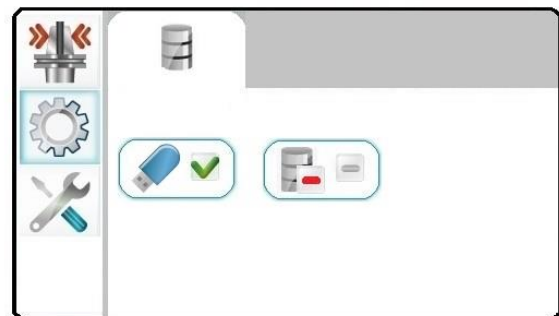

### 6.10 Reset tool memory

The tool memory may be cleared completely by pressing the button **OK**.

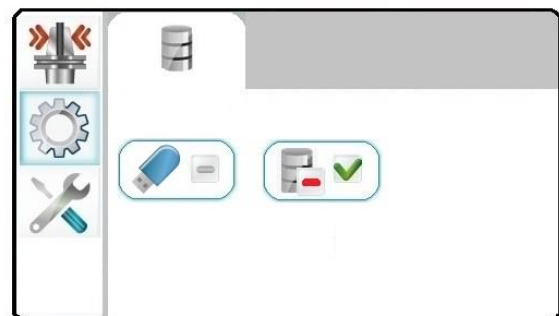



## 7 Service

With multiple pressings of **ESC** you come to the main menu.

**Shrinking**

**Configuration**

**Service**





Select with **up ▲** and **▼ down** the function **Service** and activate with **OK**.

### Information about the shrink unit

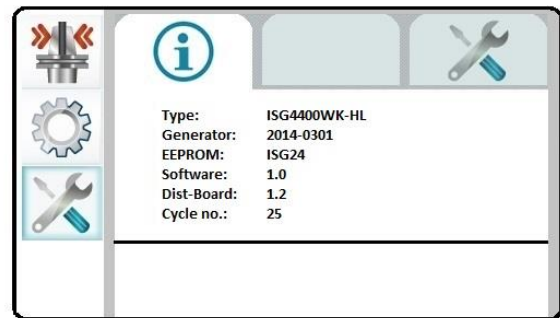
Type	equipment designation
Generator	number of the generator installed
EEPROM	version of the variable memory
Software software	version of the control panel
Dist-Board	version of distribution board
Cycle no.	number of all shrinking cycles



### Manual execution of machine functions

-  Pump on/ off (max. 5 min.)
-  Dryer on/ off
-  Cylinder up/ down

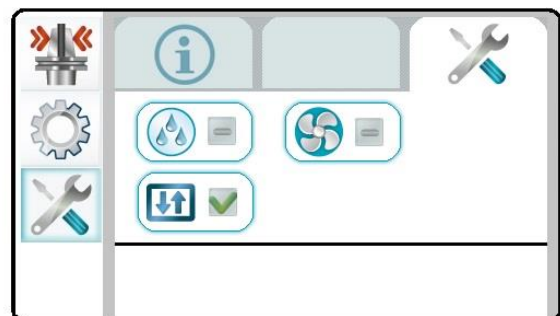

## 8 Cleaning and Servicing

### 8.1 Maintenance / Visual Inspection

Every 6 months, check mains cable for damage (visual inspection), the function of protected earth PE and the earth leakage circuit breaker (GFI, GFCI).

To check the GFCI, switch on the pump (see Chapter 0, page 40).

### 8.2 Cleaning

The unit must be cleaned regularly. To do this, switch it off at the mains and depressurize (remove the mains plug and also unplug compressed air).

The device can be cleaned on the outside using a moist cloth and standard (solvent-free) cleaning agents.

#### 8.2.1 Checking the cooling emulsion

The cooling emulsion (Synergy 905 or own products with similar contents) should be changed regularly, depending on the contamination level of tank and cooling emulsion, in order to avoid excessive contamination.

Depending on the contamination level, a system cleaner (Techniclean MTC 43 or own products with similar contents) should be used between cooling emulsion changes.

Mix the system cleaner with coolant and leave it in the tank for one day (approx. concentration of 1%). Shrinking can be carried out for one day with the system cleaner.



**The cleaner should not be left in the tank for longer than one day!  
The cleaner should not be used as addition to the cooling emulsion!**



**Keep the unit clean and clean as necessary!  
Never use compressed air or cleaning agents!**



**The unit may only be opened or repaired by manufacturer's service personnel!**



**The manufacturer only recommends the use of Synergy 905 as the emulsion and Techniclean MTC 43 as the cleaner!**

If this is not possible, only non-flammable, ester-oil-free emulsions and cleaners may be used, and the technical and chemical properties of these must match Synergy 905 and Techniclean MTC 43.

Manufacturer's details see Chapter 10.7, Safety Data Sheets.

- Synergy 905, page 58
- Techniclean MTC 43, page 62

### 8.3 Filling the coolant tank

2 liters of cooling concentrate (one initial tank filling) is provided with the unit. In general, your plant cooling emulsion with similar contents can be used.

- Fill 2 liters of coolant concentrate Synergy 905 (approx. concentration of 3%)
- Fill approx. 60 liters water into the coolant tank with a hose up to MIN-MAX range (marked at the tank)
- After filling the tank, test the cooling cycle several times in order to ensure that the coolant concentrate is 100% mixed with the water
- After this test the shrinking process can begin

### 8.4 Draining the coolant tank

To drain the cooling emulsion out of the tank use a sucking device. (see 10.3.4 Service pump, page 54)

### 8.5 Checking the float switch

- Whenever the coolant is changed, the function of the float switch must be checked. The float must move freely and it will sag down by its own weight, when the coolant tank is empty. With full coolant tank, (float under surface level) the float will stay in horizontal position, the switch is closed.
- If the float does not work properly, please clean the float switch carefully with a damp rag and mild cleaning agents. Do not damage the float. The float can be removed carefully from the fixed part, as some chips might accumulate on the magnet in the corner.
- If cleaning does not restore function, or if there is any damage to the connector or to the cable, the float switch must be replaced.
- The float switch is a safety device and must not be repaired.

### 8.6 Replacing the float switch



**Attention: prior to service the machine must be disconnected from its power supply and from the compressed air system (see Chapter 2, Safety, page 8)**

- To remove the float switch, please disconnect connector.
- Drain the coolant tank (see Chapter 8.4, Draining the coolant tank, page 43)
- Remove plastic hex nut (22mm hex) and pull the wire with the old switch through the hole
- Replace float switch and align properly, so the float hangs down. The float must move freely by its own weight. Tighten plastic hex nut with a torque of 4Nm (2.95 lbf\*ft)
- Replace connector to the generator module. Do not kink or pinch the cable. The cable should not have any tension

### **9 Contacting the Manufacturer**

These operating instructions can only serve to generally describe the function and operation of the ThermoGrip® induction generator.

To solve special problems and to carry out repairs or to make any changes not described in these operating instructions, please contact the below mentioned company who will be pleased to help you.

In case of problems or enquiries, please note the unit serial number and the software status. The serial number is located on the rating disc on the back of the unit and the software status is shown in the Service menu beneath the version numbers.

Contact us at:

**Bilz Werkzeugfabrik GmbH & Co. KG**

**Vogelsangstrasse 8**

**73760 Ostfildern**

**Germany**

**Phone +49 (711) 34801-0**

**Fax +49 (711) 348-1256**

**[www.bilz.de](http://www.bilz.de)**

Up-to-date news about ThermoGrip® can be found on the internet site.

## 10 Appendix

### 10.1 Error messages and corrective measures

Hints are displayed as follows:

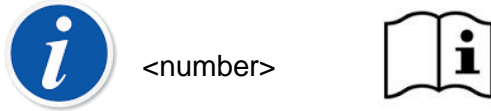

Hints serve as information for the operator and can be acknowledged using the **Stop** button!



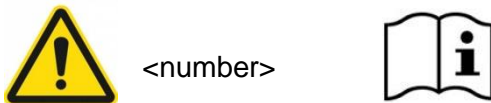















Errors are displayed as follows:































After troubleshooting, the displayed error can be acknowledged using the **Stop** button!

**Errors must only be rectified by trained personnel!**

Number	Type	Message	Possible cause	Corrective measures
		Device cannot be started up and programmed	Lack of compressed air No electric supply	Connect and/ or check the power and compressed air supply
1.1		No SD card detected in operation panel	SD card faulty or absent	Insert SD card correctly or replace it
1.2		Programmed coil and fitted coil are not identical No coil fitted	Wrong coil programmed in tool memory Coil absent or fit wrong	Change programming in tool memory or insert the correct coil Fit a coil
1.3		Temperature protection of coil 3 active	Timeout of temperature protection not finished	Wait 5 minutes until end of temperature protection
1.4		Telegram error	Connection between operation panel and distribution board faulty	Check the connections in the device
1.6		Chuck did not leave start position in time	Position switch misadjusted/ defective Lifting unit not moving freely	Check/ exchange position switch Service/ clean/ lubricate lifting unit
1.7		Chuck did not achieve end position in time	Position switch misadjusted/ defective Lifting unit not moving freely	Check/ exchange position switch Service/ clean/ lubricate lifting unit
1.8		GFCI switch of pump has been released	Pump or GFCI defective	Switch on GFCI Change pump Change GFCI
1.9		Error not acknowledged	Error occurred while shrinking and has not been acknowledged	Solve problem according to error no. and acknowledge message with <b>Stop</b> button

Number	Type	Message	Possible cause	Corrective measures
1.10		Wrong type in tool memory	Tool type wrong in set of tool memory	See manual of ToolMemoryEditor
1.11		Data carrier not recognized	Invalid set of data on data carrier Data carrier defective	Write valid set of data onto data carrier Change data carrier
1.12		Balluff reader not recognized	Balluff reader not connected Cable is defective	Connect Balluff reader to the interface Check the cable
1.13		Parity or Stop Bit Error	Balluff reader interface has misconfiguration	Correctly set up the configuration of the reader
1.14		Telegram Error	Balluff reader Telegram has invalid carrier	Correctly set up the configuration of the reader
1.15		BCC Check Digit Error	Balluff Reader Telegram has incorrect BCC check digit	Correctly set up the configuration of the reader
2.2		No USB stick in distribution board detected	USB stick faulty or absent in distribution board	Insert or replace USB stick into distribution board
2.3		File not found on USB stick	Missing file on USB stick	Copy missing file on USB stick
2.4		Wrong checksum detected in file Tool.bin	Invalid file	Reprogram file with ToolMemoryEditor
2.5	 	Float switch in coolant tank not engaged	Coolant level in tank too low Float switch fixed or hangs	Refill coolant liquid Check switch/ level
2.6		Invalid machine type	Machine type not detectable	Contact your supplier
2.7		Telegram error	Connection between distribution board and I/O-extension faulty	Check the connections in the device
2.8		Telegram error	Connection between distribution board and generator faulty	Check the connections in the device
2.10		Float switch cable not connected	Float switch cable not connected or defective	Check cable and connect to generator box
2.41		Fuse has blown	Pump or fuse are defective (Version with Opto-Coupler)	Replace fuse Replace pump
2.42		GFCI switch of pump has been released	Pump or line are defective (Version with Opto-Coupler)	Turn on GFCI switch Replace pump
2.44		Bilz-Reader not recognized on the USB interface	No reader connected Wrong or defective reader	Connect reader to USB interface or change it

Number	Type	Message	Possible cause	Corrective measures
2.45		Data reader not recognized on the USB interface	No reader connected Wrong or defective reader	Connect reader to USB interface or change it
2.46		Connection to database failed	No database connected Connection disturbed Defective Ethernet interface	Connect database Check Connection Change hardware
2.47		Data carrier ID not found in the database	Data record from data carrier has not yet been created in the database	Create data record for data carrier ID in the database
2.48		BCC error in data record from the database	Transmission error from the database	Check configuration of database
3.1		Generator not found at start-up	Generator not connected to distribution board	Check the connections in the device.
3.4		Invalid Data	Data in set of parameters corrupted	Insert correct data into tool memory with ToolMemoryEditor
3.6		Current defect in IGBT	Missing at least 1 phase Mains supply is too low or breaks down during shrinking	Check mains supply at mains receptacle in device behind the fuses
3.7		Current defect in coil	Current monitoring of the coils diagnoses over/under current	Check coil contacts Change coil
3.8	 	Safety circuit open	Coil temperature > 60°C	Leave the coil to cool down or change it Try again
3.9	 	No coil detected	Coil absent	Fit a coil
3.10		Temperature of cooling block too high to start shrinking	Temperature inside of generator is too high	Wait to cool down Try again
3.11		Temperature of cooling block too high	Temperature inside of generator is too high	Wait to cool down Try again
3.12		Relay fault	Relay of output stage doesn't close	Try again
3.13		Hardware error	Invalid generator hardware detected	Contact your supplier
3.18		Generator function stopped incorrect	Error of generator	Acknowledge error message and try again
3.22		IGOR hardware error Processor error	Error of generator	Change generator
3.23		IGOR communication error between both processors	Error of generator	Change generator

Number	Type	Message	Possible cause	Corrective measures
3.24		Relay group 1 error	Error of generator	Change generator
3.25		Relay group 2 error	Error of generator	Change generator
3.26		Relay/Fuse/Phase Error	Error of generator	Change generator
3.27		Relay/Load Resistance Error	Error of generator	Change generator
3.28		Relay test currently not working	Error of generator	Change generator
3.29		Relay test failed time out	Error of generator	Change generator
3.30		Overvoltage	Main voltage is too high	Check power
3.31		Under voltage	Main voltage is too low	Check power
3.32		Invalid coil resistance	Coil with incorrect ID used	Insert correct coil
3.33		Phase missing	Missing phase in power supply	Check power connection

Should these measures fail to start up the ISG4410WK-HL, please contact your supplier or the manufacturer's customer service.



## 10.2 Technical data



	ISG4410WK1-HL	ISG4410WK2-HL
<b>Designation of machine types:</b> 400V 480V	ISG4410WK1-HL-400V ISG4410WK1-HL-480V	ISG4410WK2-HL-400V ISG4410WK2-HL-480V
<b>El. power supply:</b> 400V 480V	3 x 400 V + N / 16 A / 50 Hz 3 x 480 V / 15 A / 60 Hz	
<b>Generator power:</b> 400V 480V	11 kW 12 kW	
<b>Usable tool shanks:</b>	CARBIDE / HSS	
<b>Maximum of tool length:</b>	500 mm (20")	700 mm (28")
<b>Clamping range Ø:</b>	3 – 50 mm ( CARBIDE ), 6 – 50 mm (HSS) 1/8" – 2" (CARBIDE), 1/4" – 2" (HSS)	
<b>Air pressure:</b>	4 bar (60 psi); dried, oil free, filtered (5 µm)	
<b>Weight (without coolant):</b>	280 kg	
<b>Dimensions:</b> Depth Width Height	580 mm 1200 mm 1850 mm	580 mm 1200 mm 2050 mm
<b>Environmental conditions:</b> Temperature Relative humidity Air pressure	+5°C ... +40°C (+40°F ... +105°F) 5% ... 85%, no condensation, no icing 86kPa ... 106kPa	

### 10.3 Scope of supply

Shrinking unit ISG4410WK-HL incl. coil and 4 ferrite discs, clamping ring, gloves as well as 2 liter coolant concentrate (corresponds to a complete filling of the coolant tank).

Ferrite discs one-piece 	For an optimal shielding of the magnetic field between coil and tool shank		
	Clamping- Ø	Designation	Ident No.
	3,0 – 5,9 mm	ISG4410	ISG4410
	6,0 – 12,0 mm	ISG4410	ISG4410
	12,1 – 22,0 mm	ISG4410	ISG4410
	22,1 – 32,0 mm	ISG4410	ISG4410
Clamping ring 	For a secure support of the ferrite disc in the coil		
		Designation	Ident No.
		ISGS309	6950431
Induction coil 	Universal coil for a clamping range of Ø 3-32 mm, which is realized with 4 ferrite discs		
	Clamping- Ø	Designation	Ident No.
	3,0 – 32,0 mm	ISGS3400-1-HL	5019318
Gloves 	For the protection from possible burns and cuts		
		Designation	Ident No.
		VA662-10	6947666
Cooling emulsion 	Cooling emulsion to protect the chuck against corrosion		
		Designation	Ident No.
	1 liter (supplied 2 liters)	Synergy 905	5085078
	System cleaner (5 liters)	Techniclean MTC 43	5046778

## 10.3.1 Available additions and optional accessories

<p>Tool holders</p> 	For the reception and correct positioning of the chuck onto the shrinking unit ISG4410WK-HL		
	Chuck-type	Designation	Ident No.
	For HSK chucks		
	HSK-25	T3-WWK/HSK25	9075293
	HSK-32	T3-WWK/HSK32	9073950
	HSK-40	T3-WWK/HSK40	9073952
	HSK-50	T3-WWK/HSK50	9073953
	HSK-63	T3-WWK/HSK63	9073954
	HSK-80	T3-WWK/HSK80	9073956
	HSK-100	T3-WWK/HSK100	9073957
	HSK-125	T3-WWK/HSK125	5060520
	For SK/ BT/ CAT chucks		
	SK30/ BT30/ CAT30	T3-WWK/SK30	9073958
	SK40/ BT40/ CAT40	T3-WWK/SK40	9073959
	SK50/ BT50/ CAT50	T3-WWK/SK50	9073961
More tool holders available on request			
<p>Induction coil</p> 	Induction coil for special applications		
	Clamping-Ø	Designation	Ident No.
	32-50 mm (2")	ISGS3400-2-HL	5019540
	32-50 mm (2")	ISGS3400-3.1-HL	
	32-50 mm (2")	ISGS3400-5-HL	5016568
	More special coils for different special tools are available on request		

Measuring adapter 	Clamping-Ø	AW	Designation	Ident No.
	6 mm	2,5	T3-M0600	6725959
	8 mm	3,0	T3-M0800	6725962
	10 mm	4,0	T3-M1000	6725963
	12 mm	5,0	T3-M1200-SW5	6726111
	14 mm	5,0	T3-M1400-SW5	6726112
	16 mm	6,0	T3-M1600	6725967
	18 mm	6,0	T3-M1800	6725968
	20 mm	8,0	T3-M2000	6725969
	25 mm	8,0	T3-M2500	6725970
	32 mm	8,0	T3-M3200	6725971
	Ferrite disc two-parts 	For application with larger cutting diameters as with the shrinking shaft diameter		
Clamping-Ø			Designation	Ident No.
3,0 – 5,9 mm			ISGS3201GT-0	9074540
6,0 – 12,0 mm			ISGS3201GT-1	9074541
12,1 – 22,0 mm			ISGS3201GT-2	9074542
Delivery disc 	For the safe storage of the ferrite disc, basic tool holders and shrunken tools			
			Designation	Ident No.
			ISG338-BG	9074029
Cooling plate for machining tools 	For depositing unshrunken tools			
			Designation	Ident No.
Coil limit stop 	Fixture used for special applications like ferrite discs two-pieces. Used as a stopper for positioning the coil when no correct positioning between ferrite disc and chuck front end will be possible.			
			Designation	Ident No.
			ISGF3414	5049287

Ferrite discs TSF			
	<p>The TSF set allows TSF chucks to be shrunk using the shrink machine.            The TSF ferrite discs provide optimal shielding of the magnetic field between coil and tool shank.            This guarantees safe and reliable shrinking of the TSF chucks.</p>		
	TSF-Set	ISGS3201-TSF-SET 9102645	
	The TSF-Set consists of the following parts		
	Clamping-Ø	Designation	Ident No.
	Storage box	TVP-ISG-TSF	6955194
	3 mm	ISGS3201-TSF03	9088924
	4 mm	ISGS3201-TSF04	9088925
	5 mm	ISGS3201-TSF05	9102646
	6 mm	ISGS3201-TSF06	9088926
	8 mm	ISGS3201-TSF08	9088927
	10 mm	ISGS3201-TSF10	9088928
	12 mm	ISGS3201-TSF12	9088980
	14 mm	ISGS3201-TSF14	9102647
	16 mm	ISGS3201-TSF16	9088981
	18 mm	ISGS3201-TSF18	9102648
	20 mm	ISGS3201-TSF20	9088982
25 mm	ISGS3201-TSF25	9088983	



Ferrite discs TER			
	TER / Clamping -Ø	Designation	Ident No.
	TER11 / 3 – 6 mm	ISGS3201-TER11-1	5095918
	TER16 / 3 – 4 mm	ISGS3201-TER16-1	5087772
	TER16 / 6 – 8 mm	ISGS3201-TER16-2	5087773
	TER20 / 6 – 10 mm	ISGS3201-TER20-1	5087774
	TER25 / 3 – 4 mm	ISGS3201-TER25-1	5087777
	TER25 / 6 – 10 mm	ISGS3201-TER25-2	5087778
	TER25 / 12 – 16 mm	ISGS3201-TER25-3	5087779
	TER32 / 6 – 8 mm	ISGS3201-TER32-1	5087780
TER32 / 10 – 20 mm	ISGS3201-TER32-2	5087781	

### 10.3.2 Length pre-setting for ThermoGrip® chucks

On request

### 10.3.3 Ejecting broken tools

The ejection unit provides easy removal of broken tools from chucks. Even tools where the point of breakage is in the tool holder can be removed without difficulty. The basic ejection tool holder can be adapted to all customary machine interfaces (HSK, SK, ABS) by means of different adaptors. Even with a tight fit (bore diameter/ tool shank) the shrunk-in shanks can be removed easily.

	Designation	Ident No.
	For HSK chucks	
	T3-WSG/HSK32	9091116
	T3-WSG/HSK40	9091118
	T3-WSG/HSK50	9091119
	T3-WSG/HSK63	9091120
	T3-WSG/HSK80	9091121
	T3-WSG/HSK100	9091124
	For SK/ BT/ CAT chucks	
	T3-WSG/SK30, BT30	9128634
	T3-WSG/SK40, BT40	9091127
	T3-WSG/SK50, BT50	9091128
	Further interfaces on request	
	Designation	Ident No.
	T3-WSG/HSK63-HSK32	9102761
	T3-WSG/HSK63-HSK40	9102762
	T3-WSG/HSK63-HSK50	5022799

### 10.3.4 Service pump

The service pump can be used to drain the cooling tank of shrink machines with water cooling. Power via 2 batteries Mono Type D 1,5 V (included).

	Designation	Ident No.
Service pump	ISGP-3V-600	5021281

## 10.4 Instructions Safety Glove

- Description:** Heat protection glove, outer layer consisting of para aramide yarn (KEVLAR) Fine knitted fabric lined with aramide felt and 100% Nornex knitted fabric
- Availability:** Size 10
- Color:** yellow
- Manufacturer:** JUTEC GmbH, Mellumstr. 23-25, D-26125 Oldenburg
- Description:** These gloves have been designed to protect your hands. They are made of the materials named above. The characteristic features of these gloves are their long service life and outstanding comfort.
- Category:** 
- Instructions:** Check that the gloves offer suitable protection for the activity you are currently performing. Select the gloves to fit the size of your hands. Remove the gloves from the wrapping.
- When using the gloves, pay attention to the following points:
- The maximum touching time depends on the area touched.  
For safety reasons this time should never exceed 5 sec.
- The open structure of these gloves means that they cannot protect your hands from punctures and impacts from pointed objects. Penetration by liquids is also possible. For protection from chemicals, gloves resistant to such substances should be worn over these gloves. Oil, grease and moisture reduce the resistance of all gloves to cutting damage and should be avoided. KEVLAR gloves are resistant to tearing. Do not use these gloves near machines with moving parts, as your hands could get pulled into the machine.
- Care and repairs:** KEVLAR gloves can be dry-cleaned or washed according to the instructions on the label. Wash in water and mild detergent at maximum 40°C. DO NOT USE softening agents, bleach or oxidizing agents, as these weaken the aramide fibers and reduce the cut-resistance of the gloves. After washing the gloves, check them carefully for any cuts and worn places. Do not use gloves which are damaged too much and can no longer be repaired, as these no longer offer adequate protection.
- Storage:** The gloves should be kept in their original wrapping in a dry, clean place. Avoid exposing the gloves to moisture or high temperatures.
- Warning:** The degree of protection required by a special task depends on the risks involved. You yourself bear final responsibility for selection of the best safety equipment for the risks involved in your workplace. Please check whether this article offers adequate protection for the jobs of work you have to perform. We offer a whole range of cut- and heat-proof KEVLAR gloves for high-risk jobs of work.

## 10.5 Mains Connections

### Allocation of the CEE socket

Pin name	Pin designation	Wire colour
L1	Phase L1	Brown
L2	Phase L2	Black/ grey
L3	Phase L3	Black
N	Neutral	Blue
PE	Ground	Green-yellow

The nominal voltages between the phases are 3x400V (-10/ +10%)

The nominal voltage between a phase L1, L2 or L3 and neutral is 230V (-10/ +10%)



#### Further hints:

- Connecting the protected earth PE and connecting the neutral N is essential!
- If an earth-leakage circuit breaker (GFI, GFCI) is used for the protection of the CEE-socket, it must be 4-polar.

### Allocation of the power cord (480V)

Pin name	Pin designation	Wire colour
L1	Phase L1	black
L2	Phase L2	orange
L3	Phase L3	red
PE	Ground wire	green

The nominal voltages between the phases are 3 x 480V (-10/ +10%)

#### Further hints:

- Connecting the protected earth PE is essential!
- This device must be connected to a circuit of 20A max. with class J fuses. It is recommended to place a fused disconnect in close proximity of the machine with lock out provision provided. We recommend placing an insulation transformer ahead of this.



## 10.6 EC Declaration of Conformity

### In accordance with the EC Machinery Directive 2006/42/EC

Bilz Werkzeugfabrik GmbH & Co. KG

declares, that the machine designated below corresponds to the following relevant directives with regard to its design and construction in the version brought into circulation.



Designation of the machine:	Induction unit
Machine type:	ISG4410WK-HL
Relevant EC directives:	EC Machinery Directive 2006/42/EC EC EMC Directive 2014/30/EC
Applied harmonized standards, in particular:	EN ISO 12100:2010 EN 60204-1:2006+A1:2009 EN 61000-6-2:2005 EN 61000-6-4:2007 + A1:2011 EN 55011:2009 + A1:2010 EN 60519-1:2011 EN 60519-3:2005
Applied national standards (USA):	FCC 47 CFR Ch. I (Edition 10-1-01), Part 18 C

In the event of any changes to the machine for which we have not been consulted, this statement becomes null and void.

#### THE COMPANY:

Company name:	Bilz Werkzeugfabrik
Legal form of company:	GmbH & Co. KG
Founding year:	1919
Register of companies:	HRA 210313, Amtsgericht Stuttgart
Headquarters:	Vogelsangstrasse 8 73760 Ostfildern Germany
Phone:	+49 (711) 34801-0
Fax:	+49 (711) 348-1256
E-Mail:	vertrieb@bilz.de
Internet:	www.bilz.de
Name of authorized representative of the technical documentation:	Bilz Werkzeugfabrik GmbH & Co. KG
Ostfildern, November 2018	
General Manager:	Michael Voss

## 10.7 Safety Data Sheets

## 10.7.1 Synergy 905

Page 1/8

Safety Data Sheet  
acc. to 29 CFR 1910.1200 (OSHA Hazcom 2012)

Blaser.  
SWISSLUBE

Issued on 09/16/2016

Edition number 7

Reviewed on 09/16/2016

## 1 Identification

## Product identifier

Trade name: **Synergy 905**

Article number: 11905-04

Relevant identified uses of the substance or mixture and uses advised against  
No further relevant information available.

Application of the substance / the preparation:

For industrial use only  
Metalworking fluid concentrate

Details of the supplier of the safety data sheet

Manufacturer / Supplier:

BLASER SWISSLUBE AG

Winterseistrasse 22

CH-3415 Hasle-Rüegsau

Switzerland

Tel.: +41 (0)34 460 01 01

Fax: +41 (0)34 460 01 00

E-mail: blaser@blaser.com

BLASER SWISSLUBE, Inc.

31 Hatfield Lane

Goshen, NY 10924

USA

Phone: +1 (0) 845 294 32 00

Fax : +1 (0) 845 294 31 02

Mailto: mailboxusa@blaser.com

Information department:

Product Safety Department

E-mail: reach@blaser.com

Emergency telephone number:

Within USA and Canada : 1-800-424-9300

Outside USA and Canada: +1-703-527-3887 (collect calls accepted)

## 2 Hazard(s) identification

## OSHA/HCS status

This material is considered hazardous by the OSHA Hazard Communication Standard (29 CFR 1910.1200).

Classification of the substance or mixture

Causes skin irritation.

Causes serious eye irritation.

May cause damage to the gastro-intestinal tract through  
prolonged or repeated exposure. Route of exposure: Oral.

## Label elements

GHS label elements The product is classified and labeled according to 29 CFR 1910.1200 (OSHA Hazcom 2012).

Hazard pictograms



GHS07 GHS08

Signal word Warning

Hazard-determining components of labeling:

Alkanolamine\*

Hazard statements

H315 Causes skin irritation.

(Contd. on page 2)  
USA

Page 2/8

Safety Data Sheet  
acc. to 29 CFR 1910.1200 (OSHA Hazcom 2012)

Blaser.  
SWISSLUBE

Issued on 09/16/2016

Edition number 7

Reviewed on 09/16/2016

Trade name: Synergy 905

H319 Causes serious eye irritation. (Contd. of page 1)

H373 May cause damage to the gastro-intestinal tract through prolonged or repeated exposure. Route of exposure:  
Oral.

## Precautionary statements

P264 Wash thoroughly after handling.

P305+P351+P338 If in eyes: Rinse cautiously with water for several minutes. Remove contact lenses, if present and  
easy to do. Continue rinsing.

P332+P313 If skin irritation occurs: Get medical advice/attention.

P337+P313 If eye irritation persists: Get medical advice/attention.

P314 Get medical advice/attention if you feel unwell.

P501 Dispose of contents/container in accordance with local/regional/national/international regulations.

Other hazards None

## 3 Composition/information on ingredients

## Chemical characterization: Mixtures

Description: Mixture of nitrogen-containing organic acids (salts) and inhibitors

## Declarable components:

CAS no.		
Confidential	Carboxylic acids, neutralized with alkanolamines*	>5.0- <15%
CAS: 102-71-6	Triethanolamine	>5.0-9.9%
EINECS: 203-049-8		
CAS: 57-55-6	Propylene glycol	>1.0-4.9%
EINECS: 200-338-0		
Confidential	Alkanolamine*	>1.0-4.9%
Proprietary	Benzotriazole*	< 2.00%

## Additional information:

\* Neutralization product: equilibrium of ion pairs.

The specific chemical identity and/or exact percentage concentration of proprietary components is withheld as a trade secret.

## 4 First-aid measures

## Description of first aid measures

## General information:

Immediately remove any clothing soiled by the product.

Symptoms of poisoning may even occur after several hours; therefore medical observation for at least 48 hours after the accident.

## After inhalation:

In case of unconsciousness place patient stably in side position for transportation.

Not applicable, as the concentrate is not volatile.

After skin contact: Immediately wash with water and soap and rinse thoroughly.

After eye contact: Rinse opened eye for several minutes under running water. If symptoms persist, consult a doctor.

## After swallowing:

Do not induce vomiting; immediately call for medical help.

A person vomiting while lying on their back should be turned onto their side.

## Information for doctor:

Most important symptoms and effects, both acute and delayed Nausea / vomiting

Indication of any immediate medical attention and special treatment needed

If swallowed or in case of vomiting, danger of entering the lungs.

Medical supervision for at least 48 hours.

USA  
(Contd. on page 3)

Page 3/8

**Safety Data Sheet**  
acc. to 29 CFR 1910.1200 (OSHA Hazcom 2012)

**Blaser.**  
SWISSLINE

Issued on 09/16/2016

Edition number 7

Reviewed on 09/16/2016

Trade name: Synergy 905

(Contd. of page 2)

**5 Fire-fighting measures****Extinguishing media**

Suitable extinguishing agents: CO<sub>2</sub>, extinguishing powder or water spray. Fight larger fires with water spray.  
For safety reasons unsuitable extinguishing agents: Water with full jet  
**Special hazards arising from the substance or mixture**  
During heating or in case of fire poisonous gases are produced.  
**Advice for firefighters**  
**Protective equipment:** Mouth respiratory protective device.  
**Additional information** Cool endangered receptacles with water spray.

**6 Accidental release measures**

**Personal precautions, protective equipment and emergency procedures** Mount respiratory protective device.  
**Environmental precautions:** Do not allow to enter sewers/ surface or ground water.  
**Methods and material for containment and cleaning up:**  
Absorb with liquid-binding material (sand, diatomite, acid binders, universal binders, sawdust).  
Dispose contaminated material as waste according to item 13.  
Ensure adequate ventilation.  
**Reference to other sections**  
See Section 7 for information on safe handling.  
See Section 8 for information on personal protection equipment.  
See Section 13 for disposal information.

**7 Handling and storage**

**Handling:**  
**Precautions for safe handling**  
Ensure good ventilation/exhaustion at the workplace.  
Prevent formation of aerosols.  
The product has been classified and marked in accordance with directives on hazardous materials.  
Observe the general safety regulations when handling chemicals.  
**Information about protection against explosions and fires:** Keep respiratory protective device available.  
**Conditions for safe storage, including any incompatibilities**  
**Storage:**  
**Requirements to be met by storerooms and receptacles:** Store only in the original receptacle.  
**Information about storage in one common storage facility:**  
Do not store together with oxidizing and acidic materials.  
**Further information about storage conditions:**  
Protect from heat and direct sunlight.  
Optimal storage temperature between 32°F and 104°F  
Minimum shelf life: In closed, original container, at least 12 months.  
**Specific end use(s)** No further relevant information available.

**8 Exposure controls/personal protection**

**Additional information about design of technical systems:** No further data; see item 7.  
**Control parameters**  
**Components with limit values at the workplace:**  
NIOSH Recommended exposure limit for Metalworking fluids: 0.5 mg/m<sup>3</sup> (particulate)

**102-71-6 Triethanolamine**

TLV (US)	Long-term value: 5 mg/m <sup>3</sup>
EL (Canada)	Long-term value: 5 mg/m <sup>3</sup>
EV (Canada)	Long-term value: 3.1 mg/m <sup>3</sup> , 0.5 ppm

(Contd. on page 4)

Page 4/8

**Safety Data Sheet**  
acc. to 29 CFR 1910.1200 (OSHA Hazcom 2012)

**Blaser.**  
SWISSLINE

Issued on 09/16/2016

Edition number 7

Reviewed on 09/16/2016

Trade name: Synergy 905

(Contd. of page 3)

TLV (USA)	Long-term value: 5 mg/m <sup>3</sup>
57-55-6 Propylene glycol	
EV (Canada)	Long-term value: 155* 10** mg/m <sup>3</sup> , 50* ppm *vapour and aerosol;**aerosol only
WEEL (USA)	Long-term value: 10 mg/m <sup>3</sup>

**Additional information:** The lists that were valid during the creation were used as basis.**Exposure controls****Personal protective equipment:****General protective and hygienic measures:**

Keep away from foodstuffs, beverages and feed.  
Immediately remove all soiled and contaminated clothing.  
Wash hands before breaks and at the end of work.  
Store protective clothing separately.  
**Respiratory Protection:** Not required.

**Protection of hands:**

Protective gloves

The glove material has to be impermeable and resistant to the product/ the substance/ the preparation.  
Due to missing tests no recommendation to the glove material can be given for the product/ the preparation/ the chemical mixture.

**Selection of the glove material on consideration of the penetration times, rates of diffusion and the degradation**  
**Material of gloves (recommended):** Suitable protective gloves: Nitrile gloves, minimum thickness of 0.3 mm.

**Breakthrough time of glove material:**

The exact breakthrough time has to be found out by the manufacturer of the protective gloves and has to be observed.

**Eye protection (recommended):**

Eye protector with side protection (framed eyeglasses) ANSI Z87.1 – 2010

**Use of tight fitting goggles**

**Body protection (recommended):** Protective work clothing

**9 Physical and chemical properties****Information on basic physical and chemical properties****General Information****Appearance:**

Form:	Fluid
Color:	Yellow
Odor:	Weak, characteristic
Odor threshold:	Not determined.

**pH-value:** 8.7 - 9.0 @ 5% in H<sub>2</sub>O (DIN 51369 / ASTM D1287)

**Change in condition:**

Melting point/Melting range:	Not applicable
Boiling point/Boiling range:	>100 °C (>212 °F) (DIN 51751 / ASTM D86)

**Flash point:** 144 °C (291 °F) (ISO 2592 / ASTM D92)

Not applicable (contains water).

**Evaporation rate:** Not determined.

**Flammability (solid, gaseous):** Not applicable.

**Explosion limits (@1013 mbar):**

Lower:	Not determined.
Upper:	Not determined.

(Contd. on page 5)

Page 5/8

**Safety Data Sheet**  
 acc. to 29 CFR 1910.1200 (OSHA Hazcom 2012)

**Blaser.**  
 SWISSLINE

Issued on 09/16/2016

Edition number 7

Reviewed on 09/16/2016

Trade name: Synergy 905

(Contd. of page 4)

<b>Oxidizing properties</b>	Not applicable.
<b>Vapor pressure:</b>	Not determined.
<b>Refractive index:</b>	1.404
<b>Relative density</b>	1.06 @ 68°F (20 °C) (DIN 51757 / ASTM D1217)
<b>Vapor density</b>	Not applicable.
<b>Evaporation rate</b>	Not determined.
<b>Solubility in / Miscibility with Water:</b>	Emulsifiable.
<b>Partition coefficient (n-octanol/water):</b>	Not determined.
<b>Auto-ignition temperature:</b>	Product is not selfigniting.
<b>Decomposition temperature:</b>	Not determined.
<b>Viscosity</b>	
<b>Kinematic at 40 °C (104 °F):</b>	5.8 mm <sup>2</sup> /s (ISO 3104 / ASTM D445)
<b>VOC content:</b>	164 g/l (ASTM E1868-10); Concentrate in the packaging as sold.
	24.6 g/l (ASTM E1868-10) @ Maximum concentration 15%
<b>Solvent content:</b>	13.8 %
<b>Other information:</b>	none

**10 Stability and reactivity**

Reactivity None known if used as directed.  
 Chemical stability Stable under recommended storage conditions.  
 Thermal decomposition / conditions to be avoided: No decomposition if used according to specifications.  
 Possibility of hazardous reactions Reacts with strong acids and oxidizing agents.  
 Conditions to avoid No further relevant information available.  
 Incompatible materials: No further relevant information available.  
 Hazardous decomposition products (in case of fire or oxidation):  
 Carbon monoxide and carbon dioxide  
 Nitrogen oxides (NO<sub>x</sub>)

**11 Toxicological information**

## Information on toxicological effects

## Acute toxicity:

LD/LC50 values that are relevant for classification:

\* pure substance

Alkanolamine*		
Oral	LD50	> 2000 mg/kg (rat)
	No Observed Adverse Effect Level	>31.25 mg/kg bw/day (rat)
Dicyclohexylamine*		
Oral	LD50	200 mg/kg (rat)
Dermal	LD50	200-316 mg/kg (rabbit)
31075-24-8 Poly quaternary ammonium chloride		
Oral	LD50	1951 mg/kg (rat)
Dermal	LD50	>2000 mg/kg (rabbit)
Inhalative	LD50	2.9 mg/L (rat)

Primary irritant effect:  
 on the skin: Causes skin irritation.  
 on the eye: Irritating effect.

(Contd. on page 6)

Page 6/8

**Safety Data Sheet**  
 acc. to 29 CFR 1910.1200 (OSHA Hazcom 2012)

**Blaser.**  
 SWISSLINE

Issued on 09/16/2016

Edition number 7

Reviewed on 09/16/2016

Trade name: Synergy 905

(Contd. of page 5)

**Sensitization:** No sensitizing effects known.  
**Additional toxicological information:**  
 The product shows the following dangers according to internally approved calculation methods for preparations:  
 Irritant

<b>IARC (International Agency for Research on Cancer)</b>	
102-71-6 Triethanolamine	3
<b>NTP (National Toxicology Program)</b>	
None of the ingredients are listed.	

**12 Ecological information**

## Toxicity

## Aquatic toxicity:

\* pure substance

Benzotriazole*	
LC50/96h	180 mg/l (Brachydanio rerio)
NOEC/21d	0.97 mg/l (Daphnia galeata)
NOEC/10d	3.94 mg/l (Lemna minor)
EC50/48h	63-91 mg/L (Daphnia magna)
Dicyclohexylamine*	
LC50/96h	62 mg/l (Danio rerio)
	12 mg/l (Oryzias latipes)
EC50/48h	201 mg/L (Bak)
	8 mg/L (Daphnia magna)
31075-24-8 Poly quaternary ammonium chloride	
LC50/96h	0.047 mg/l (Oncorhynchus mykiss) (OECD 203)
EC50/48h	0.37 mg/L (Daphnia magna) (OECD 202)
EC50/72h	0.0019 mg/L (Algae) (OECD 201)

Persistence and degradability No further relevant information available.

Behavior in environmental systems:

Bioaccumulative potential No further relevant information available.

Mobility in soil No further relevant information available.

Additional ecological information:

General notes:

Do not allow product to reach ground water, water course or sewage system.

Danger to drinking water if even small quantities leak into the ground.

Results of PBT and vPvB assessment

PBT: Not applicable.

vPvB: Not applicable.

Other adverse effects No further relevant information available.

**13 Disposal considerations**

Waste treatment methods

Recommendation:

Must not be disposed of together with household garbage. Do not allow product to reach sewage system.

Used containers

Recommendation: Disposal must be made according to official regulations.

(Contd. on page 7)

Trade name: Synergy 905

(Contd. of page 6)

**14 Transport information**

UN-Number	
DOT, IMDG, IATA	not applicable
DOT, IMDG, IATA	not applicable
DOT, IMDG, IATA	
Hazard Classification:	not applicable
DOT, IMDG, IATA	not applicable
<b>Environmental hazards</b>	
Marine pollutant (according to IMDG):	No
Special precautions for user	Not applicable.
<b>Transport/Additional information:</b> Not hazardous according to the above specifications.	
IATA	IATA Dangerous Goods Regulation (DGR) 57th Edition 2016
UN "Model Regulation":	not applicable

**15 Regulatory information**

<b>Safety, health and environmental regulations/legislation specific for the substance or mixture:</b>	
SARA (Superfund Amendments and Reauthorization)	
Section 355 (extremely hazardous substances):	None of the ingredients are listed.
Section 313 (Specific toxic chemical listings):	This product does not contain a chemical that are listed in Section 313.
TSCA (Toxic Substances Control Act):	All ingredients are listed on the U.S. TSCA inventory or exempt from premanufacture notice requirements.
California Proposition 65	This product does not intentionally contain any chemicals known by the State of California to cause cancer and/or birth defects. Moreover, we do not routinely analyze its products for impurities which may be such chemicals.
Chemicals known to cause cancer:	None of the ingredients are listed.
Chemicals known to cause reproductive toxicity for females:	None of the ingredients are listed.
Chemicals known to cause reproductive toxicity for males:	None of the ingredients are listed.
Chemicals known to cause developmental toxicity:	None of the ingredients are listed.
<b>Carcinogenic categories:</b>	
EPA (Environmental Protection Agency)	None of the ingredients are listed.
NIOSH-Carcinogen list	None of the ingredients are listed.
California SCAQMD Rule 1144: Category: Metalworking Fluid – Metal Forming – General. Recordkeeping requirement: Super Compliant. GHS label elements GHS label elements are issued under section 2.	

(Contd. on page 8)

Trade name: Synergy 905

(Contd. of page 7)

**16 Other information**

This information is based on our present knowledge. However, this shall not constitute a guarantee for any specific product features and shall not establish a legally valid contractual relationship.

H.R.2420:

RoHS:

This product fulfill the H.R.2420 requirements in that the EDEC Act regulated materials are absent or their concentrations are significantly below regulatory thresholds.

NFPA ratings (scale 0-4)



HMIS ratings (0-4)



Department issuing SDS: Product Stewardship

Editor's notice:

The above mentioned data correspond to our present state of knowledge and experience. The safety data sheet serves as description of the products in regard to necessary safety measures. The indications have not the meaning of guarantees on properties.

Date of preparation / last revision 09/16/2016 / 6

Abbreviations and acronyms:

- RoHS: Restriction of Hazardous Substances
- ADR: Accord européen sur le transport des marchandises dangereuses par Route (European Agreement concerning the International Carriage of Dangerous Goods by Road)
- IMDG: International Maritime Code for Dangerous Goods
- DOT: US Department of Transportation
- IATA: International Air Transport Association
- GHS: Globally Harmonised System of Classification and Labelling of Chemicals
- ACGIH: American Conference of Governmental Industrial Hygienists
- CAS: Chemical Abstracts Service (division of the American Chemical Society)
- VOC: Volatile Organic Compounds (USA, EU)
- ISO: International Organisation for Standardisation
- LC50: Lethal concentration, 50 percent
- LD50: Lethal dose, 50 percent
- PBT: Persistent, Bioaccumulative and Toxic chemicals
- vPvB: very Persistent and very Bioaccumulative chemicals
- NIOSH: National Institute for Occupational Safety and Health
- OSHA: Occupational Safety and Health Administration
- ATE: Acute Toxicity Estimate
- Skin Irrit. 2: Skin corrosion/irritation – Category 2
- Eye Irrit. 2A: Serious eye damage/eye irritation – Category 2A
- STOT RE 2: Specific target organ toxicity (repeated exposure) – Category 2
- \* Data compared to the previous version altered.

The asterisk (\*) on the left side indicate the respective changes from the previous version.

USA

### 10.7.2 Techniclean MTC 43

Conforms to Regulation (EC) No. 1907/2006 (REACH), Annex II, as amended by Commission Regulation (EU) 2015/830

**SAFETY DATA SHEET**



**SECTION 1: Identification of the substance/mixture and of the company/undertaking**

**1.1 Product identifier**

**Product name** Techniclean MTC 43  
**Product code** 462650-DE02  
**SDS no.** 462650  
**Product type** Liquid.

**1.2 Relevant identified uses of the substance or mixture and uses advised against**

Identified uses

Use of lubricants and greases in open systems-Industrial  
 Use of lubricants and greases in open systems-Professional

**Use of the substance/mixture** Cleaner.  
 For specific application advice see appropriate Technical Data Sheet or consult our company representative.

**1.3 Details of the supplier of the safety data sheet**

**Supplier** Castrol (UK) Limited  
 PO Box 352,  
 Chertsey Road,  
 Sunbury On Thames,  
 Middlesex,  
 TW16 9AW Orders/Enquiries: 0845 9645111 Technical Enquiries: 0845 9000209  
**E-mail address** MSDSadvice@bp.com

**1.4 Emergency telephone number**

**EMERGENCY TELEPHONE NUMBER** Carechem: +44 (0) 1235 239 670 (24/7)

**SECTION 2: Hazards identification**

**2.1 Classification of the substance or mixture**

**Product definition** Mixture  
**Classification according to Regulation (EC) No. 1272/2008 [CLP/GHS]**  
 Skin Irrit. 2, H315  
 Eye Dam. 1, H318  
 Aquatic Chronic 3, H412

**Additional Information** CLP: Not classified as hazardous when diluted below 5%  
 See Section 16 for the full text of the H statements declared above.  
 See sections 11 and 12 for more detailed information on health effects and symptoms and environmental hazards.

**2.2 Label elements**

**Hazard pictograms**



**Signal word** Danger  
**Hazard statements** H318 - Causes serious eye damage.  
 H315 - Causes skin irritation.  
 H412 - Harmful to aquatic life with long lasting effects.

**Precautionary statements**

**Prevention** P280 - Wear protective gloves. Wear eye or face protection.  
 P273 - Avoid release to the environment.

<b>Product name</b> Techniclean MTC 43	<b>Product code</b> 462650-DE02	<b>Page:</b> 1/17
<b>Version</b> 2.02	<b>Date of issue</b> 3 January 2017	<b>Format</b> United Kingdom (UK) (United Kingdom)
	<b>Language</b> ENGLISH	

Conforms to Regulation (EC) No. 1907/2006 (REACH), Annex II, as amended by Commission Regulation (EU) 2015/830

**SECTION 2: Hazards identification**

**Response** P332 + P313 - If skin irritation occurs: Get medical attention.  
 P305 + P351 + P338 - IF IN EYES: Rinse cautiously with water for several minutes. Immediately call a POISON CENTER or physician.

**Storage** Not applicable.

**Disposal** P501 - Dispose of contents and container in accordance with all local, regional, national and international regulations.

**Hazardous ingredients** (ethylenedioxy)dimethanol alcohols, C8-10, ethers with polyethylene-polypropylene glycol monobenzyl ether

**Supplemental label elements** Not applicable.

**EU Regulation (EC) No. 1907/2006 (REACH)**

**Annex XVII - Restrictions on the manufacture, placing on the market and use of certain dangerous substances, mixtures and articles** Not applicable.

**Special packaging requirements** Containers to be fitted with child-resistant fastenings

**Tactile warning of danger** Not applicable.

**Other hazards which do not result in classification** Defatting to the skin.

**Other hazards which do not result in classification** Defatting to the skin.

**Other hazards which do not result in classification** Defatting to the skin.

**Other hazards which do not result in classification** Defatting to the skin.

**Other hazards which do not result in classification** Defatting to the skin.

**Other hazards which do not result in classification** Defatting to the skin.

**Other hazards which do not result in classification** Defatting to the skin.

**Other hazards which do not result in classification** Defatting to the skin.

**Other hazards which do not result in classification** Defatting to the skin.

**Other hazards which do not result in classification** Defatting to the skin.

**Other hazards which do not result in classification** Defatting to the skin.

**Other hazards which do not result in classification** Defatting to the skin.

**Other hazards which do not result in classification** Defatting to the skin.

**Other hazards which do not result in classification** Defatting to the skin.

**Other hazards which do not result in classification** Defatting to the skin.

**Other hazards which do not result in classification** Defatting to the skin.

**Other hazards which do not result in classification** Defatting to the skin.

**Other hazards which do not result in classification** Defatting to the skin.

**Other hazards which do not result in classification** Defatting to the skin.

**Other hazards which do not result in classification** Defatting to the skin.

**Other hazards which do not result in classification** Defatting to the skin.

**Other hazards which do not result in classification** Defatting to the skin.

**Other hazards which do not result in classification** Defatting to the skin.

**Other hazards which do not result in classification** Defatting to the skin.

**Other hazards which do not result in classification** Defatting to the skin.

**Other hazards which do not result in classification** Defatting to the skin.

**Other hazards which do not result in classification** Defatting to the skin.

**Other hazards which do not result in classification** Defatting to the skin.

**Other hazards which do not result in classification** Defatting to the skin.

**Other hazards which do not result in classification** Defatting to the skin.

**Other hazards which do not result in classification** Defatting to the skin.

**Other hazards which do not result in classification** Defatting to the skin.

**Other hazards which do not result in classification** Defatting to the skin.

**Other hazards which do not result in classification** Defatting to the skin.

**Other hazards which do not result in classification** Defatting to the skin.

**Other hazards which do not result in classification** Defatting to the skin.

**Other hazards which do not result in classification** Defatting to the skin.

**Other hazards which do not result in classification** Defatting to the skin.

**Other hazards which do not result in classification** Defatting to the skin.

**Other hazards which do not result in classification** Defatting to the skin.

**Other hazards which do not result in classification** Defatting to the skin.

**Other hazards which do not result in classification** Defatting to the skin.

**Other hazards which do not result in classification** Defatting to the skin.

**Other hazards which do not result in classification** Defatting to the skin.

**Other hazards which do not result in classification** Defatting to the skin.

**Other hazards which do not result in classification** Defatting to the skin.

**Other hazards which do not result in classification** Defatting to the skin.

**Other hazards which do not result in classification** Defatting to the skin.

**Other hazards which do not result in classification** Defatting to the skin.

**Other hazards which do not result in classification** Defatting to the skin.

**Other hazards which do not result in classification** Defatting to the skin.

**Other hazards which do not result in classification** Defatting to the skin.

**Other hazards which do not result in classification** Defatting to the skin.

**Other hazards which do not result in classification** Defatting to the skin.

**Other hazards which do not result in classification** Defatting to the skin.

**Other hazards which do not result in classification** Defatting to the skin.

**Other hazards which do not result in classification** Defatting to the skin.

**Other hazards which do not result in classification** Defatting to the skin.

<b>Product name</b> Techniclean MTC 43	<b>Product code</b> 462650-DE02	<b>Page:</b> 2/17
<b>Version</b> 2.02	<b>Date of issue</b> 3 January 2017	<b>Format</b> United Kingdom (UK) (United Kingdom)
	<b>Language</b> ENGLISH	

Conforms to Regulation (EC) No. 1907/2006 (REACH), Annex II, as amended by Commission Regulation (EU) 2015/830

## SECTION 3: Composition/information on ingredients

- [1] Substance classified with a health or environmental hazard
- [2] Substance with a workplace exposure limit
- [3] Substance meets the criteria for PBT according to Regulation (EC) No. 1907/2006, Annex XIII
- [4] Substance meets the criteria for vPvB according to Regulation (EC) No. 1907/2006, Annex XIII
- [5] Substance of equivalent concern

Occupational exposure limits, if available, are listed in Section 8.

## SECTION 4: First aid measures

### 4.1 Description of first aid measures

<b>Eye contact</b>	In case of contact, immediately flush eyes with plenty of water for at least 15 minutes. Eyelids should be held away from the eyeball to ensure thorough rinsing. Check for and remove any contact lenses. Chemical burns must be treated promptly by a physician. Get medical attention immediately.
<b>Skin contact</b>	Wash skin thoroughly with soap and water or use recognised skin cleanser. Remove contaminated clothing and shoes. Wash clothing before reuse. Clean shoes thoroughly before reuse. Get medical attention.
<b>Inhalation</b>	If inhaled, remove to fresh air. Get medical attention if symptoms appear. In case of inhalation of decomposition products in a fire, symptoms may be delayed. The exposed person may need to be kept under medical surveillance for 48 hours.
<b>Ingestion</b>	Do not induce vomiting unless directed to do so by medical personnel. Never give anything by mouth to an unconscious person. If unconscious, place in recovery position and get medical attention immediately. Wash out mouth with water if person is conscious. Get medical attention if symptoms occur.
<b>Protection of first-aiders</b>	No action shall be taken involving any personal risk or without suitable training. If it is suspected that fumes are still present, the rescuer should wear an appropriate mask or self-contained breathing apparatus. It may be dangerous to the person providing aid to give mouth-to-mouth resuscitation. Wash contaminated clothing thoroughly with water before removing it, or wear gloves.

### 4.2 Most important symptoms and effects, both acute and delayed

See Section 11 for more detailed information on health effects and symptoms.

### 4.3 Indication of any immediate medical attention and special treatment needed

<b>Notes to physician</b>	Treatment should in general be symptomatic and directed to relieving any effects. In case of inhalation of decomposition products in a fire, symptoms may be delayed. The exposed person may need to be kept under medical surveillance for 48 hours.
---------------------------	---

## SECTION 5: Firefighting measures

### 5.1 Extinguishing media

<b>Suitable extinguishing media</b>	Use foam or all-purpose dry chemical to extinguish.
<b>Unsuitable extinguishing media</b>	Do not use water jet.

### 5.2 Special hazards arising from the substance or mixture

<b>Hazards from the substance or mixture</b>	In a fire or if heated, a pressure increase will occur and the container may burst.
<b>Hazardous combustion products</b>	Combustion products may include the following: carbon oxides (CO, CO <sub>2</sub> ) (carbon monoxide, carbon dioxide) nitrogen oxides (NO, NO <sub>2</sub> , etc.)

### 5.3 Advice for firefighters

<b>Special precautions for fire-fighters</b>	Promptly isolate the scene by removing all persons from the vicinity of the incident if there is a fire. No action shall be taken involving any personal risk or without suitable training. This material is harmful to aquatic organisms. Fire water contaminated with this material must be contained and prevented from being discharged to any waterway, sewer or drain.
<b>Special protective equipment for fire-fighters</b>	Fire-fighters should wear appropriate protective equipment and self-contained breathing apparatus (SCBA) with a full face-piece operated in positive pressure mode. Clothing for fire-fighters (including helmets, protective boots and gloves) conforming to European standard EN 469 will provide a basic level of protection for chemical incidents.

Product name	Technidean MTC 43	Product code	462650-DE02	Page:	3/17
Version	2.02	Date of issue	3 January 2017	Format	United Kingdom (UK) (United Kingdom)
				Language	ENGLISH

Conforms to Regulation (EC) No. 1907/2006 (REACH), Annex II, as amended by Commission Regulation (EU) 2015/830

## SECTION 6: Accidental release measures

### 6.1 Personal precautions, protective equipment and emergency procedures

<b>For non-emergency personnel</b>	No action shall be taken involving any personal risk or without suitable training. Evacuate surrounding areas. Keep unnecessary and unprotected personnel from entering. Do not touch or walk through spilled material. Floors may be slippery; use care to avoid falling. Do not breathe vapour or mist. Provide adequate ventilation. Put on appropriate personal protective equipment. Contact emergency personnel.
<b>For emergency responders</b>	Entry into a confined space or poorly ventilated area contaminated with vapour, mist or fume is extremely hazardous without the correct respiratory protective equipment and a safe system of work. Wear self-contained breathing apparatus. Wear a suitable chemical protective suit. Chemical resistant boots. See also the information in 'For non-emergency personnel'.

### 6.2 Environmental precautions

Avoid dispersal of spill material and runoff and contact with soil, waterways, drains and sewers. Inform the relevant authorities if the product has caused environmental pollution (sewers, waterways, soil or air). Water polluting material. May be harmful to the environment if released in large quantities.

### 6.3 Methods and material for containment and cleaning up

<b>Small spill</b>	Stop leak if without risk. Move containers from spill area. Absorb with an inert material and place in an appropriate waste disposal container. Dispose of via a licensed waste disposal contractor.
<b>Large spill</b>	Stop leak if without risk. Move containers from spill area. Approach the release from upwind. Prevent entry into sewers, water courses, basements or confined areas. Contain and collect spillage with non-combustible, absorbent material e.g. sand, earth, vermiculite or diatomaceous earth and place in container for disposal according to local regulations. Contaminated absorbent material may pose the same hazard as the spill product. Dispose of via a licensed waste disposal contractor.

### 6.4 Reference to other sections

See Section 1 for emergency contact information.  
See Section 5 for firefighting measures.  
See Section 8 for information on appropriate personal protective equipment.  
See Section 12 for environmental precautions.  
See Section 13 for additional waste treatment information.

## SECTION 7: Handling and storage

The information in this section contains generic advice and guidance. The list of Identified Uses in Section 1 should be consulted for any available use-specific information provided in the Exposure Scenario(s).

### 7.1 Precautions for safe handling

<b>Protective measures</b>	Put on appropriate personal protective equipment. Do not breathe vapour or mist. Do not ingest. Avoid contact of spill material and runoff with soil and surface waterways. If during normal use the material presents a respiratory hazard, use only with adequate ventilation or wear appropriate respirator. Keep in the original container or an approved alternative made from a compatible material, kept tightly closed when not in use. Do not reuse container. Empty containers retain product residue and can be hazardous. Use only with adequate ventilation. Do not get in eyes, on skin or on clothing.
----------------------------	---

### Advice on general occupational hygiene

Eating, drinking and smoking should be prohibited in areas where this material is handled, stored and processed. Wash thoroughly after handling. Remove contaminated clothing and protective equipment before entering eating areas. See also Section 8 for additional information on hygiene measures.

### 7.2 Conditions for safe storage, including any incompatibilities

Store between the following temperatures: 5 to 40°C (41 to 104°F). Store in accordance with local regulations. Store in a dry, cool and well-ventilated area, away from incompatible materials (see Section 10). Store locked up. Keep away from heat and direct sunlight. Keep container tightly closed and sealed until ready for use. Containers that have been opened must be carefully resealed and kept upright to prevent leakage. Store and use only in equipment/containers designed for use with this product. Do not store in unlabelled containers. Use appropriate containment to avoid environmental contamination.

### 7.3 Specific end use(s)

See section 1.2 and Exposure scenarios in annex, if applicable.

Product name	Technidean MTC 43	Product code	462650-DE02	Page:	4/17
Version	2.02	Date of issue	3 January 2017	Format	United Kingdom (UK) (United Kingdom)
				Language	ENGLISH

Conforms to Regulation (EC) No. 1907/2006 (REACH), Annex II, as amended by Commission Regulation (EU) 2015/830

## SECTION 8: Exposure controls/personal protection

The information in this section contains generic advice and guidance. The list of Identified Uses in Section 1 should be consulted for any available use-specific information provided in the Exposure Scenario(s).

### 8.1 Control parameters

#### Occupational exposure limits

Product/ingredient name	Exposure limit values
dipropylene glycol methyl ether	EH40/2005 WELs (United Kingdom (UK)): Absorbed through skin. TWA: 308 mg/m <sup>3</sup> 5 hours. Issued/Revised: 2/2000 TWA: 50 ppm 8 hours. Issued/Revised: 2/2000

Whilst specific OELs for certain components may be shown in this section, other components may be present in any mist, vapour or dust produced. Therefore, the specific OELs may not be applicable to the product as a whole and are provided for guidance only.

This product contains a preservative that may release trace amounts of formaldehyde during use.

**Recommended monitoring procedures**  
If this product contains ingredients with exposure limits, personal, workplace atmosphere or biological monitoring may be required to determine the effectiveness of the ventilation or other control measures and/or the necessity to use respiratory protective equipment. Reference should be made to monitoring standards, such as the following: European Standard EN 689 (Workplace atmospheres - Guidance for the assessment of exposure by inhalation to chemical agents for comparison with limit values and measurement strategy) European Standard EN 14042 (Workplace atmospheres - Guide for the application and use of procedures for the assessment of exposure to chemical and biological agents) European Standard EN 482 (Workplace atmospheres - General requirements for the performance of procedures for the measurement of chemical agents) Reference to national guidance documents for methods for the determination of hazardous substances will also be required.

#### Derived No Effect Level

No DNELs/DMELs available.

#### Predicted No Effect Concentration

No PNECs available

### 8.2 Exposure controls

#### Appropriate engineering controls

Provide exhaust ventilation or other engineering controls to keep the relevant airborne concentrations below their respective occupational exposure limits.  
All activities involving chemicals should be assessed for their risks to health, to ensure exposures are adequately controlled. Personal protective equipment should only be considered after other forms of control measures (e.g. engineering controls) have been suitably evaluated. Personal protective equipment should conform to appropriate standards, be suitable for use, be kept in good condition and properly maintained.  
Your supplier of personal protective equipment should be consulted for advice on selection and appropriate standards. For further information contact your national organisation for standards. The final choice of protective equipment will depend upon a risk assessment. It is important to ensure that all items of personal protective equipment are compatible.

#### Individual protection measures

##### Hygiene measures

Wash hands, forearms and face thoroughly after handling chemical products, before eating, smoking and using the lavatory and at the end of the working period. Ensure that eyewash stations and safety showers are close to the workstation location.

##### Respiratory protection

Use with adequate ventilation.  
In case of insufficient ventilation, wear suitable respiratory equipment.  
Recommended: half-face mask - inorganic gases/vapor filter (Type B) - particulate filter.  
The correct choice of respiratory protection depends upon the chemicals being handled, the conditions of work and use, and the condition of the respiratory equipment. Safety procedures should be developed for each intended application. Respiratory protection equipment should therefore be chosen in consultation with the supplier/manufacturer and with a full assessment of the working conditions.

##### Eye/face protection

Chemical splash goggles.

##### Skin protection

##### Hand protection

General Information:

Because specific work environments and material handling practices vary, safety procedures should be developed for each intended application. The correct choice of protective gloves depends upon the chemicals being handled, and the conditions of work and use. Most gloves provide protection for only a limited time before they must be discarded and replaced (even the best chemically resistant gloves will break down after repeated chemical exposures).

Product name	Technidean MTC 43	Product code	402050-DE02	Page:	9/17
Version	2.02	Date of issue	3 January 2017	Format	United Kingdom (UK) (United Kingdom)
				Language	ENGLISH

Conforms to Regulation (EC) No. 1907/2006 (REACH), Annex II, as amended by Commission Regulation (EU) 2015/830

## SECTION 8: Exposure controls/personal protection

Gloves should be chosen in consultation with the supplier / manufacturer and taking account of a full assessment of the working conditions.

Wear suitable gloves.  
Recommended: Butyl gloves.  
Breakthrough time:

Breakthrough time data are generated by glove manufacturers under laboratory test conditions and represent how long a glove can be expected to provide effective permeation resistance. It is important when following breakthrough time recommendations that actual workplace conditions are taken into account. Always consult with your glove supplier for up-to-date technical information on breakthrough times for the recommended glove type.  
Our recommendations on the selection of gloves are as follows:

#### Continuous contact:

Gloves with a minimum breakthrough time of 240 minutes, or >480 minutes if suitable gloves can be obtained.  
If suitable gloves are not available to offer that level of protection, gloves with shorter breakthrough times may be acceptable as long as appropriate glove maintenance and replacement regimes are determined and adhered to.

#### Short-term / splash protection:

Recommended breakthrough times as above.  
It is recognised that for short-term, transient exposures, gloves with shorter breakthrough times may commonly be used. Therefore, appropriate maintenance and replacement regimes must be determined and rigorously followed.

#### Glove Thickness:

For general applications, we recommend gloves with a thickness typically greater than 0.35 mm.

It should be emphasised that glove thickness is not necessarily a good predictor of glove resistance to a specific chemical, as the permeation efficiency of the glove will be dependent on the exact composition of the glove material. Therefore, glove selection should also be based on consideration of the task requirements and knowledge of breakthrough times.  
Glove thickness may also vary depending on the glove manufacturer, the glove type and the glove model. Therefore, the manufacturers' technical data should always be taken into account to ensure selection of the most appropriate glove for the task.

Note: Depending on the activity being conducted, gloves of varying thickness may be required for specific tasks. For example:

- Thinner gloves (down to 0.1 mm or less) may be required where a high degree of manual dexterity is needed. However, these gloves are only likely to give short duration protection and would normally be just for single use applications, then disposed of.
- Thicker gloves (up to 3 mm or more) may be required where there is a mechanical (as well as a chemical) risk i.e. where there is abrasion or puncture potential.

#### Skin and body

Use of protective clothing is good industrial practice.  
Personal protective equipment for the body should be selected based on the task being performed and the risks involved and should be approved by a specialist before handling this product.  
Cotton or polyester/cotton overalls will only provide protection against light superficial contamination that will not soak through to the skin. Overalls should be laundered on a regular basis. When the risk of skin exposure is high (e.g. when cleaning up spillages or if there is a risk of splashing) then chemical resistant aprons and/or impervious chemical suits and boots will be required.

#### Refer to standards:

Respiratory protection: EN 529  
Gloves: EN 420, EN 374  
Eye protection: EN 166  
Filtering half-mask: EN 149  
Filtering half-mask with valve: EN 405  
Half-mask: EN 140 plus filter  
Full-face mask: EN 136 plus filter  
Particulate filters: EN 143  
Gas/combined filters: EN 14387

Product name	Technidean MTC 43	Product code	402050-DE02	Page:	9/17
Version	2.02	Date of issue	3 January 2017	Format	United Kingdom (UK) (United Kingdom)
				Language	ENGLISH



Conforms to Regulation (EC) No. 1907/2006 (REACH), Annex II, as amended by Commission Regulation (EU) 2015/830

#### SECTION 8: Exposure controls/personal protection

**Environmental exposure controls** Emissions from ventilation or work process equipment should be checked to ensure they comply with the requirements of environmental protection legislation. In some cases, fume scrubbers, filters or engineering modifications to the process equipment will be necessary to reduce emissions to acceptable levels.

#### SECTION 9: Physical and chemical properties

##### 9.1 Information on basic physical and chemical properties

###### Appearance

Physical state	Liquid.
Colour	Yellow. [Light]
Odour	Not available.
Odour threshold	Not available.
pH	8.8 [Conc. (% w/w): 5%]
Melting point/freezing point	Not available.
Initial boiling point and boiling range	Not available.
Flash point	Open cup: >100°C (>212°F) [Estimated. Water content interferes with flash point determination.]
Evaporation rate	Not available.
Flammability (solid, gas)	Not available.
Upper/lower flammability or explosive limits	Not available.
Vapour pressure	Not available.
Vapour density	Not available.
Relative density	Not available.
Density	>1000 kg/m <sup>3</sup> (>1 g/cm <sup>3</sup> ) at 20°C
Solubility(ies)	Soluble in water.
Partition coefficient: n-octanol/water	Not available.
Auto-ignition temperature	Not available.
Decomposition temperature	Not available.
Viscosity	Kinematic: 5.1 mm <sup>2</sup> /s (5.1 cSt) at 40°C
Explosive properties	Not available.
Oxidising properties	Not available.

##### 9.2 Other information

No additional information.

#### SECTION 10: Stability and reactivity

10.1 Reactivity	No specific test data available for this product. Refer to Conditions to avoid and Incompatible materials for additional information.
10.2 Chemical stability	The product is stable.
10.3 Possibility of hazardous reactions	Under normal conditions of storage and use, hazardous reactions will not occur. Under normal conditions of storage and use, hazardous polymerisation will not occur.
10.4 Conditions to avoid	High temperatures
10.5 Incompatible materials	Reactive or incompatible with the following materials: oxidising materials. Slightly reactive or incompatible with the following materials: acids.
10.6 Hazardous decomposition products	Under normal conditions of storage and use, hazardous decomposition products should not be produced.

Product name	Technidean MTC 43	Product code	462650-DE02	Page:	7/17
Version	2.02	Date of issue	3 January 2017	Format	United Kingdom (UK) (United Kingdom)
				Language	ENGLISH

Conforms to Regulation (EC) No. 1907/2006 (REACH), Annex II, as amended by Commission Regulation (EU) 2015/830

#### SECTION 11: Toxicological information

##### 11.1 Information on toxicological effects

###### Acute toxicity estimates

Route	ATE value
Oral	5854.1 mg/kg
Dermal	22000 mg/kg

Information on likely routes of exposure Routes of entry anticipated: Dermal, Inhalation.

###### Potential acute health effects

Inhalation	May give off gas, vapour or dust that is very irritating or corrosive to the respiratory system. Exposure to decomposition products may cause a health hazard. Serious effects may be delayed following exposure. May cause irritation to eyes, nose and throat due to exposure to vapour, mists or fumes.
Ingestion	Irritating to mouth, throat and stomach.
Skin contact	Causes skin irritation. Defatting to the skin.
Eye contact	Causes serious eye damage.

###### Symptoms related to the physical, chemical and toxicological characteristics

Inhalation	No specific data.
Ingestion	Adverse symptoms may include the following: stomach pains
Skin contact	Adverse symptoms may include the following: pain or irritation redness dryness cracking blistering may occur
Eye contact	Adverse symptoms may include the following: pain watering redness

###### Delayed and immediate effects as well as chronic effects from short and long-term exposure

Inhalation	Overexposure to the inhalation of airborne droplets or aerosols may cause irritation of the respiratory tract.
Ingestion	Ingestion of large quantities may cause nausea and diarrhoea.
Skin contact	Prolonged or repeated contact can defat the skin and lead to irritation and/or dermatitis.
Eye contact	Potential risk of transient stinging or redness if accidental eye contact occurs.

###### Potential chronic health effects

General	No known significant effects or critical hazards.
Carcinogenicity	No known significant effects or critical hazards.
Mutagenicity	No known significant effects or critical hazards.
Developmental effects	No known significant effects or critical hazards.
Fertility effects	No known significant effects or critical hazards.

#### SECTION 12: Ecological information

12.1 Toxicity	
Environmental hazards	Harmful to aquatic life with long lasting effects.
12.2 Persistence and degradability	Expected to be biodegradable.
12.3 Bioaccumulative potential	Not available.
12.4 Mobility in soil	
Soil/water partition coefficient (K <sub>ow</sub> )	Not available.
Mobility	Liquid. Soluble in water.

Product name	Technidean MTC 43	Product code	462650-DE02	Page:	8/17
Version	2.02	Date of issue	3 January 2017	Format	United Kingdom (UK) (United Kingdom)
				Language	ENGLISH

Conforms to Regulation (EC) No. 1907/2006 (REACH), Annex II, as amended by Commission Regulation (EU) 2015/830

**SECTION 12: Ecological information**

**12.5 Results of PBT and vPvB assessment**

PBT Not applicable.  
vPvB Not applicable.

12.6 Other adverse effects No known significant effects or critical hazards.

**SECTION 13: Disposal considerations**

The information in this section contains generic advice and guidance. The list of Identified Uses in Section 1 should be consulted for any available use-specific information provided in the Exposure Scenario(s).

**13.1 Waste treatment methods**

**Product**

Methods of disposal Where possible, arrange for product to be recycled. Dispose of via an authorised person/ licensed waste disposal contractor in accordance with local regulations.

Hazardous waste Yes.

**European waste catalogue (EWC)**

Waste code	Waste designation
12 03 01*	aqueous washing liquids

However, deviation from the intended use and/or the presence of any potential contaminants may require an alternative waste disposal code to be assigned by the end user.

**Packaging**

Methods of disposal Where possible, arrange for product to be recycled. Dispose of via an authorised person/ licensed waste disposal contractor in accordance with local regulations.

Waste code	European waste catalogue (EWC)
15 01 10*	packaging containing residues of or contaminated by hazardous substances

**Special precautions**

This material and its container must be disposed of in a safe way. Care should be taken when handling emptied containers that have not been cleaned or rinsed out. Empty containers or liners may retain some product residues. Empty containers represent a fire hazard as they may contain flammable product residues and vapour. Never weld, solder or braze empty containers. Avoid dispersal of spill material and runoff and contact with soil, waterways, drains and sewers.

**SECTION 14: Transport information**

	ADR/RID	ADN	IMDG	IATA
14.1 UN number	Not regulated.	Not regulated.	Not regulated.	Not regulated.
14.2 UN proper shipping name	-	-	-	-
14.3 Transport hazard class(es)	-	-	-	-
14.4 Packing group	-	-	-	-
14.5 Environmental hazards	No.	No.	No.	No.
Additional information	-	-	-	-

14.6 Special precautions for user Not available.

14.7 Transport in bulk according to Annex II of Marpol and the IBC Code Not available.

Product name	Technidean MTC 43	Product code	402050-DE02	Page:	9/17
Version	2.02	Date of issue	3 January 2017	Format	United Kingdom (UK) (United Kingdom)
				Language	ENGLISH

Conforms to Regulation (EC) No. 1907/2006 (REACH), Annex II, as amended by Commission Regulation (EU) 2015/830

**SECTION 15: Regulatory information**

15.1 Safety, health and environmental regulations/legislation specific for the substance or mixture

**EU Regulation (EC) No. 1907/2006 (REACH)**

**Annex XIV - List of substances subject to authorisation**

**Substances of very high concern**

None of the components are listed.

**Other regulations**

REACH Status The company, as identified in Section 1, sells this product in the EU in compliance with the current requirements of REACH.

United States inventory (TSCA 8b) All components are listed or exempted.

Australia inventory (AICS) All components are listed or exempted.

Canada inventory All components are listed or exempted.

China inventory (IECSC) All components are listed or exempted.

Japan inventory (ENCS) All components are listed or exempted.

Korea inventory (KECI) All components are listed or exempted.

Philippines inventory (PICCS) All components are listed or exempted.

Taiwan Chemical Substances Inventory (TCSI) All components are listed or exempted.

15.2 Chemical safety assessment

This product contains substances for which Chemical Safety Assessments are still required.

**SECTION 16: Other information**

**Abbreviations and acronyms**

ADN = European Provisions concerning the International Carriage of Dangerous Goods by Inland Waterway  
ADR = The European Agreement concerning the International Carriage of Dangerous Goods by Road  
ATE = Acute Toxicity Estimate  
BCF = Bioconcentration Factor  
CAS = Chemical Abstracts Service  
CLP = Classification, Labelling and Packaging Regulation (Regulation (EC) No. 1272/2008)  
CSA = Chemical Safety Assessment  
CSR = Chemical Safety Report  
DMEL = Derived Minimal Effect Level  
DNEL = Derived No Effect Level  
EINECS = European Inventory of Existing Commercial chemical Substances  
ES = Exposure Scenario  
EUH statement = CLP-specific Hazard statement  
EWC = European Waste Catalogue  
GHS = Globally Harmonized System of Classification and Labelling of Chemicals  
IATA = International Air Transport Association  
IBC = Intermediate Bulk Container  
IMDG = International Maritime Dangerous Goods  
LogPow = logarithm of the octanol/water partition coefficient  
MARPOL = International Convention for the Prevention of Pollution From Ships, 1973 as modified by the Protocol of 1978. ("Marpol" = marine pollution)  
OECD = Organisation for Economic Co-operation and Development  
PBT = Persistent, Bioaccumulative and Toxic  
PNEC = Predicted No Effect Concentration  
RID = The Regulations concerning the International Carriage of Dangerous Goods by Rail  
RRN = REACH Registration Number  
SADT = Self-Accelerating Decomposition Temperature  
SVHC = Substances of Very High Concern  
STOT-RE = Specific Target Organ Toxicity - Repeated Exposure  
STOT-SE = Specific Target Organ Toxicity - Single Exposure  
TWA = Time weighted average  
UN = United Nations  
UVCB = Complex hydrocarbon substance  
VOC = Volatile Organic Compound  
vPvB = Very Persistent and Very Bioaccumulative

Product name	Technidean MTC 43	Product code	402050-DE02	Page:	10/17
Version	2.02	Date of issue	3 January 2017	Format	United Kingdom (UK) (United Kingdom)
				Language	ENGLISH

Conforms to Regulation (EC) No. 1907/2006 (REACH), Annex II, as amended by Commission Regulation (EU) 2015/830

## SECTION 16: Other information

Varies = may contain one or more of the following 101316-69-2 / RRN 01-2119486048-13, 101316-70-5, 101316-71-6, 101316-72-7 / RRN 01-2119486999-06, 04741-58-4 / RRN 01-2119488708-23, 04741-59-5 / RRN 01-2119487067-30, 04741-95-3 / RRN 01-2119487081-40, 04741-96-4 / RRN 01-2119483621-38, 04741-97-5 / RRN 01-2119480374-36, 04742-01-4 / RRN 01-2119488707-21, 04742-44-5 / RRN 01-2119886177-24, 04742-45-6, 04742-52-0 / RRN 01-2119467170-46, 04742-53-0 / RRN 01-2119480375-34, 04742-54-7 / RRN 01-2119484927-25, 04742-55-3 / RRN 01-2119487077-20, 04742-56-9 / RRN 01-2119480132-48, 04742-57-0 / RRN 01-2119489287-22, 04742-58-1, 04742-62-7 / RRN 01-2119480472-38, 04742-63-8, 04742-64-9, 04742-65-0 / RRN 01-2119471299-27, 04742-70-7 / RRN 01-2119487080-42, 72623-85-9 / RRN 01-2119555262-43, 72623-86-0 / RRN 01-2119474878-18, 72623-87-1 / RRN 01-2119474869-13, 74869-22-0 / RRN 01-2119485601-39, 60669-74-2 / RRN 01-2119970171-43

### Full text of abbreviated H statements

H302	Harmful if swallowed.
H312	Harmful in contact with skin.
H315	Causes skin irritation.
H318	Causes serious eye damage.
H319	Causes serious eye irritation.
H332	Harmful if inhaled.
H400	Very toxic to aquatic life.
H410	Very toxic to aquatic life with long lasting effects.

### Full text of classifications [CLP/GHS]

Acute Tox. 4, H302	ACUTE TOXICITY (oral) - Category 4
Acute Tox. 4, H312	ACUTE TOXICITY (dermal) - Category 4
Acute Tox. 4, H332	ACUTE TOXICITY (inhalation) - Category 4
Aquatic Acute 1, H400	ACUTE AQUATIC HAZARD - Category 1
Aquatic Chronic 1, H410	LONG-TERM AQUATIC HAZARD - Category 1
Eye Dam. 1, H318	SERIOUS EYE DAMAGE/EYE IRRITATION - Category 1
Eye Irrit. 2, H319	SERIOUS EYE DAMAGE/EYE IRRITATION - Category 2
Skin Irrit. 2, H315	SKIN CORROSION/IRRITATION - Category 2

### History

Date of issue/ Date of revision 03/01/2017.

Date of previous issue 23/12/2016.

Prepared by Product Stewardship

Indicates information that has changed from previously issued version.

### Notice to reader

All reasonably practicable steps have been taken to ensure this data sheet and the health, safety and environmental information contained in it is accurate as of the date specified below. No warranty or representation, express or implied is made as to the accuracy or completeness of the data and information in this data sheet.

The data and advice given apply when the product is sold for the stated application or applications. You should not use the product other than for the stated application or applications without seeking advice from BP Group.

It is the user's obligation to evaluate and use this product safely and to comply with all applicable laws and regulations. The BP Group shall not be responsible for any damage or injury resulting from use, other than the stated product use of the material, from any failure to adhere to recommendations, or from any hazards inherent in the nature of the material. Purchasers of the product for supply to a third party for use at work, have a duty to take all necessary steps to ensure that any person handling or using the product is provided with the information in this sheet. Employers have a duty to tell employees and others who may be affected of any hazards described in this sheet and of any precautions that should be taken. You can contact the BP Group to ensure that this document is the most current available. Alteration of this document is strictly prohibited.

Product name	Techniclean MTC 43	Product code	402650-DE02	Page:	11/17
Version	2.02	Date of issue	3 January 2017	Format	United Kingdom (UK) (United Kingdom)
				Language	ENGLISH



## Annex to the extended Safety Data Sheet (eSDS)

Industrial

### Identification of the substance or mixture

Product definition	Mixture
Code	402650-DE02
Product name	Techniclean MTC 43

### Section 1: Title

Short title of the exposure scenario Use of lubricants and greases in open systems - Industrial

List of use descriptors Identified use name: Use of lubricants and greases in open systems-Industrial  
 Process Category: PROC01, PROC02, PROC07, PROC08b, PROC09, PROC10, PROC13  
 Sector of end use: SU03  
 Subsequent service life relevant for that use: No.  
 Environmental Release Category: ERC04  
 Specific Environmental Release Category: ATIEL-ATC SPERC 4.Cl.v1

### Processes and activities covered by the exposure scenario

Covers use of lubricants and greases in open systems, including application of lubricant to work pieces or equipment by dipping, brushing or spraying (without exposure to heat), e.g. mould releases, corrosion protection, slideways. Includes associated product storage, material transfers, sampling and maintenance activities.

## Section 2 Operational conditions and risk management measures

### Section 2.1 Control of worker exposure

#### Product characteristics:

Physical state:	Liquid, vapour pressure < 0.5 kPa
Concentration of substance in product:	Covers use of substance/product up to 100 % (unless stated differently)
Frequency and duration of use:	Covers daily exposures up to 8 hours
Other conditions affecting workers exposure:	Assumes use at not more than 20°C above ambient temperature, unless stated differently. Assumes a good basic standard of occupational hygiene is implemented

#### Contributing scenarios: Operational conditions and risk management measures

The following information provides minimum risk management measures for the contributing scenarios identified within this lubricant use group. However, more detailed information on control measures e.g. specific glove types may be documented in Section 8 of the main body of this safety data sheet. Please review Section 5 in conjunction with the information on this Generic Exposure Scenario.

#### General measures applicable to all activities:

Avoid direct skin contact with product. Identify potential areas for indirect skin contact. Wear gloves (tested to EN 374) if hand contact with substance likely. Clean up contamination/spills as soon as they occur. Wash off any skin contamination immediately. Provide basic employee training to prevent/minimise exposures and to report any skin problems that may develop. Other skin protection measures such as impervious suits and face shields may be required during high dispersion activities which are likely to lead to substantial aerosol release, e.g. spraying.

#### Material transfers Manual:

Avoid carrying out activities involving exposure for more than 1 hour.

Material transfers Automated process with (semi) closed systems: Ensure material transfers are under containment or extract ventilation.

#### Roller, spreader, flow application:

Provide extract ventilation to points where emissions occur.

#### Spraying:

Carry out in a vented booth or extracted enclosure.

#### Treatment by dipping and pouring:

Provide a good standard of controlled ventilation (10 to 15 air changes per hour). Wear chemical-resistant gloves (tested to EN374) in combination with specific activity training.

Techniclean MTC 43

Use of lubricants and greases in open systems - Industrial

12/17

Equipment cleaning and maintenance:  
 Drain down system prior to equipment break-in or maintenance. Provide a good standard of general ventilation (not less than 3 to 5 air changes per hour). Wear chemical-resistant gloves (tested to EN374) in combination with specific activity training. Retain drain-downs in sealed storage pending disposal or for subsequent recycle.

Storage:  
 Store substance within a closed system.

**Section 2.2: Control of environmental exposure**

<b>Product characteristics:</b>	Applicability domain: product in which the risk determining substance has the following hazard profile: LogKow: Vapour pressure: PNEC Freshwater aquatic range (mg/L):
<b>Amounts used:</b>	
EU tonnage of risk determining substance per year:	3.81E+01 Tonnes/year
<b>Frequency and duration of use:</b>	
Emission days	300
<b>Environment factors not influenced by risk management:</b>	
Local freshwater dilution factor	10
Local marine water dilution factor	100
<b>Other conditions affecting environmental exposure:</b>	Negligible wastewater emissions as process operates without water contact.
Release fraction to air (after typical onsite RMMs)	5.00E-05
Release fraction to soil from process (after typical onsite RMMs)	0
Release fraction to wastewater from process (after typical onsite RMMs and before sewage treatment plan)	No data available yet
<b>Technical conditions and measures at process level (source) to prevent release:</b>	Common practices vary across sites thus conservative process release estimates used.
<b>Technical on-site conditions and measures to reduce or limit discharges, air emissions and releases to soil:</b>	Prevent discharge of undissolved substance to or recover from onsite wastewater. User sites are assumed to be provided with oil/water separators and waste water to be discharged via a sewage treatment plant
<b>Organisational measures to prevent/limit release from site:</b>	Do not apply industrial sludge to natural soils. Sewage sludge should be incinerated, contained or reclaimed.
<b>Conditions and measures related to sewage treatment plant:</b>	
Estimated substance removal from wastewater via on-site sewage treatment	No data available yet
Assumed domestic sewage treatment plant flow rate (m3/d)	2.00E+3
Maximum allowable site tonnage (M <sub>site</sub> ) based on release following total wastewater treatment removal	No data available yet
Maximum allowable site tonnage (M <sub>site</sub> ) based on release following total wastewater treatment removal as product:	No data available yet
<b>Conditions and measures related to external treatment of waste for disposal:</b>	External treatment and disposal of waste should comply with applicable local and/or national regulations.
<b>Conditions and measures related to external recovery of waste:</b>	External recovery and recycling of waste should comply with applicable local and/or national regulations.

Techniclean MTC 43      Use of lubricants and greases in open systems - Industrial  
 13/17

**Section 3: EXPOSURE ESTIMATION AND REFERENCE TO ITS SOURCE**

<b>Exposure estimation and reference to its source - Environment</b>	
Exposure assessment (environment):	Used ECETOC TRA model (May 2010 release).
<b>Exposure estimation and reference to its source - Workers</b>	
Exposure assessment (human):	The ECETOC TRA tool has been used to estimate workplace exposures unless otherwise indicated.

**Section 4: Guidance to check compliance with the exposure scenario**

<b>Environment</b>	Guidance is based on assumed operating conditions which may not be applicable to all sites; thus, scaling may be necessary to define appropriate site-specific risk management measures. Further details on scaling and control technologies are provided in SPERC factsheet. If scaling reveals a condition of unsafe use (i.e., RCRs > 1), additional RMMs or a site-specific chemical safety assessment is required. For further information see <a href="http://www.ATIEL.org/REACH_GES">www.ATIEL.org/REACH_GES</a>
<b>Health</b>	Where other risk management measures/operational conditions are adopted, then users should ensure that risks are managed to at least equivalent levels.

Techniclean MTC 43      Use of lubricants and greases in open systems - Industrial  
 14/17



**Annex to the extended Safety Data Sheet (eSDS)**

Professional

**Identification of the substance or mixture**

Product definition: Mixture  
 Code: 462850-DE02  
 Product name: Techniclean MTC 43

**Section 1: Title**

Short title of the exposure scenario: Use of lubricants and greases in open systems - Professional  
 List of use descriptors: Identified use name: Use of lubricants and greases in open systems-Professional  
 Process Category: PROC01, PROC02, PROC08a, PROC10, PROC11, PROC13  
 Sector of end use: SU22  
 Subsequent service life relevant for that use: No.  
 Environmental Release Category: ERC08a, ERC08d  
 Specific Environmental Release Category: ATIEL-ATC SPERC 8 Cp.v1

Processes and activities covered by the exposure scenario: Covers use of lubricants and greases in open systems, including application of lubricant to work pieces or equipment by dipping, brushing or spraying (without exposure to heat), e.g. mould releases, corrosion protection, slideways. Includes associated product storage, material transfers, sampling and maintenance activities.  
 Assessment Method: See Section 3

**Section 2 Operational conditions and risk management measures**

**Section 2.1 Control of worker exposure**

Physical state: Liquid, vapour pressure < 0.5 kPa  
 Amounts used: Covers use of substance/product up to 100 % (unless stated differently)  
 Frequency and duration of use: Covers daily exposures up to 8 hours  
 Other conditions affecting workers exposure: Assumes use at not more than 20°C above ambient temperature, unless stated differently.  
 Assumes a good basic standard of occupational hygiene is implemented

**Contributing scenarios: Operational conditions and risk management measures**

General measures applicable to all activities: Avoid direct skin contact with product. Identify potential areas for indirect skin contact. Wear gloves (tested to EN 374) if hand contact with substance likely. Clean up contamination/spills as soon as they occur. Wash off any skin contamination immediately. Provide basic employee training to prevent/minimise exposures and to report any skin problems that may develop. Use suitable eye protection. Avoid direct eye contact with product also via contamination on hands.  
 Material transfers Manual: Avoid carrying out activities involving exposure for more than 1 hour.  
 Roller, spreader, flow application: Natural ventilation is from doors, windows etc. Controlled ventilation means air is supplied or removed by a powered fan. Avoid carrying out activities involving exposure for more than 4 hours. Wear chemical-resistant gloves (tested to EN374) in combination with specific activity training.  
 Spraying: Natural ventilation is from doors, windows etc. Controlled ventilation means air is supplied or removed by a powered fan. Avoid carrying out activities involving exposure for more than 1 hour. Wear a respirator conforming to EN140 with type AP2 filter or better. Wear suitable coveralls to prevent exposure to the skin. Wear chemical-resistant gloves (tested to EN374) in combination with specific activity training.  
 Treatment by dipping and pouring: Natural ventilation is from doors, windows etc. Controlled ventilation means air is supplied or removed by a powered fan.  
 Equipment cleaning and maintenance: Drain down system prior to equipment break-in or maintenance. Natural ventilation is from doors, windows etc. Controlled ventilation means air is supplied or removed by a powered fan. Avoid carrying out activities involving exposure for more than 4 hours. Retain drain-downs in sealed storage pending disposal or for subsequent recycle.  
 Storage: Store substance within a closed system.

Techniclean MTC 43 Use of lubricants and greases in open systems - Professional 15/17

**Section 2.2: Control of environmental exposure**

Product characteristics: Applicability domain: product in which the risk determining substance has the following hazard profile:  
 LogKow:  
 Vapour pressure:  
 PNEC Freshwater aquatic range (mg/L): 2.24E+01 Tonnes/year  
 Amounts used:  
 Frequency and duration of use:  
 Emission days: 365  
 Environment factors not influenced by risk management:  
 Local freshwater dilution factor: 10  
 Local marine water dilution factor: 100  
 Other conditions affecting environmental exposure: Negligible wastewater emissions as process operates without water contact.  
 Release fraction to air (after typical onsite RMMs): 1.00E-04  
 Release fraction to soil from process (after typical onsite RMMs): 1E-03  
 Release fraction to wastewater from process (after typical onsite RMMs and before sewage treatment plan): No data available yet  
 Technical conditions and measures at process level (source) to prevent release: Common practices vary across sites thus conservative process release estimates used.  
 Technical on-site conditions and measures to reduce or limit discharges, air emissions and releases to soil: Prevent discharge of undissolved substance to or recover from onsite wastewater.  
 Organisational measures to prevent/limit release from site: Do not apply industrial sludge to natural soils. Sewage sludge should be incinerated, contained or reclaimed.  
 Conditions and measures related to sewage treatment plant:  
 Estimated substance removal from wastewater via on-site sewage treatment: No data available yet  
 Maximum allowable site tonnage (M<sub>site</sub>) based on release following total wastewater treatment removal: No data available yet  
 Conditions and measures related to external treatment of waste for disposal: External treatment and disposal of waste should comply with applicable local and/or national regulations.  
 Conditions and measures related to external recovery of waste: External recovery and recycling of waste should comply with applicable local and/or national regulations.

**Section 3: EXPOSURE ESTIMATION AND REFERENCE TO ITS SOURCE**

Exposure estimation and reference to its source - Environment  
 Exposure assessment (environment): Used ECETOC TRA model (May 2010 release).  
 Exposure estimation and reference to its source - Workers  
 Exposure assessment (human): The ECETOC TRA tool has been used to estimate workplace exposures unless otherwise indicated.

**Section 4: Guidance to check compliance with the exposure scenario**

Environment  
 Guidance is based on assumed operating conditions which may not be applicable to all sites; thus, scaling may be necessary to define appropriate site-specific risk management measures. Further details on scaling and control technologies are provided in SPERC factsheet. If scaling reveals a condition of unsafe use (i.e., RCRs > 1), additional RMMs or a site-specific chemical safety assessment is required. For further information see www.ATIEL.org/REACH\_GES

Techniclean MTC 43 Use of lubricants and greases in open systems - Professional 16/17

Health

Where other risk management measures/operational conditions are adopted, then users should ensure that risks are managed to at least equivalent levels.

Techniclean MTC 43

Use of lubricants and greases in open systems -  
Professional  
17/17

**10.8 Table of Fuses for 400V units**

Fuse	Phases	Rated Voltage	Rated Current	Frequency	Dimensions	Tripping Characteristic	Location
F1	1	250V	3.15A	50/60 Hz	5x20 mm	fast acting	Distribution board
F2	1	250V	3.15A	50/60 Hz	5x20 mm	fast acting	Distribution board
F3	1	250V	3.15A	50/60 Hz	5x20 mm	fast acting	Distribution board
FS1	1	250V	4A	50/60 Hz	5x20 mm	fast acting	24VDC Power supply
F101	1	500V	16A	50/60 Hz	10x38 mm - 13/32" x 1-1/2"	fast acting	Generator
F102	1	500V	16A	50/60 Hz	10x38 mm - 13/32" x 1-1/2"	fast acting	Generator
F103	1	500V	16A	50/60 Hz	10x38 mm - 13/32" x 1-1/2"	fast acting	Generator
F104	1	500V	0.5A	50/60 Hz	6.3x32 mm - 1/4" x 1-1/4"	fast acting	Generator
F105	1	500V	0.5A	50/60 Hz	6.3x32 mm - 1/4" x 1-1/4"	fast acting	Generator
F106	1	500V	0.5A	50/60 Hz	6.3x32 mm - 1/4" x 1-1/4"	fast acting	Generator

**10.9 Table of Fuses for 480V units**

Fuse	Phases	Rated Voltage	Rated Current	Frequency	Dimensions	Tripping Characteristic	Location
F1	1	250V	3.15A	50/60 Hz	5x20 mm	fast acting	Distribution board
F2	1	250V	3.15A	50/60 Hz	5x20 mm	fast acting	Distribution board
F3	1	250V	3.15A	50/60 Hz	5x20 mm	fast acting	Distribution board
FS1	1	250V	4A	50/60 Hz	5x20 mm	fast acting	24VDC Power supply
F7	1	600V	3A	50/60 Hz	10x38 mm - 13/32" x 1-1/2"	time lag	Transformer input
F8	1	600V	3A	50/60 Hz	10x38 mm - 13/32" x 1-1/2"	time lag	Transformer input
F101	1	600V	15A	50/60 Hz	10x38 mm - 13/32" x 1-1/2"	fast acting	Generator
F102	1	600V	15A	50/60 Hz	10x38 mm - 13/32" x 1-1/2"	fast acting	Generator
F103	1	600V	15A	50/60 Hz	10x38 mm - 13/32" x 1-1/2"	fast acting	Generator
F104	1	500V	0.5A	50/60 Hz	6.3x32 mm - 1/4" x 1-1/4"	fast acting	Generator
F105	1	500V	0.5A	50/60 Hz	6.3x32 mm - 1/4" x 1-1/4"	fast acting	Generator
F106	1	500V	0.5A	50/60 Hz	6.3x32 mm - 1/4" x 1-1/4"	fast acting	Generator





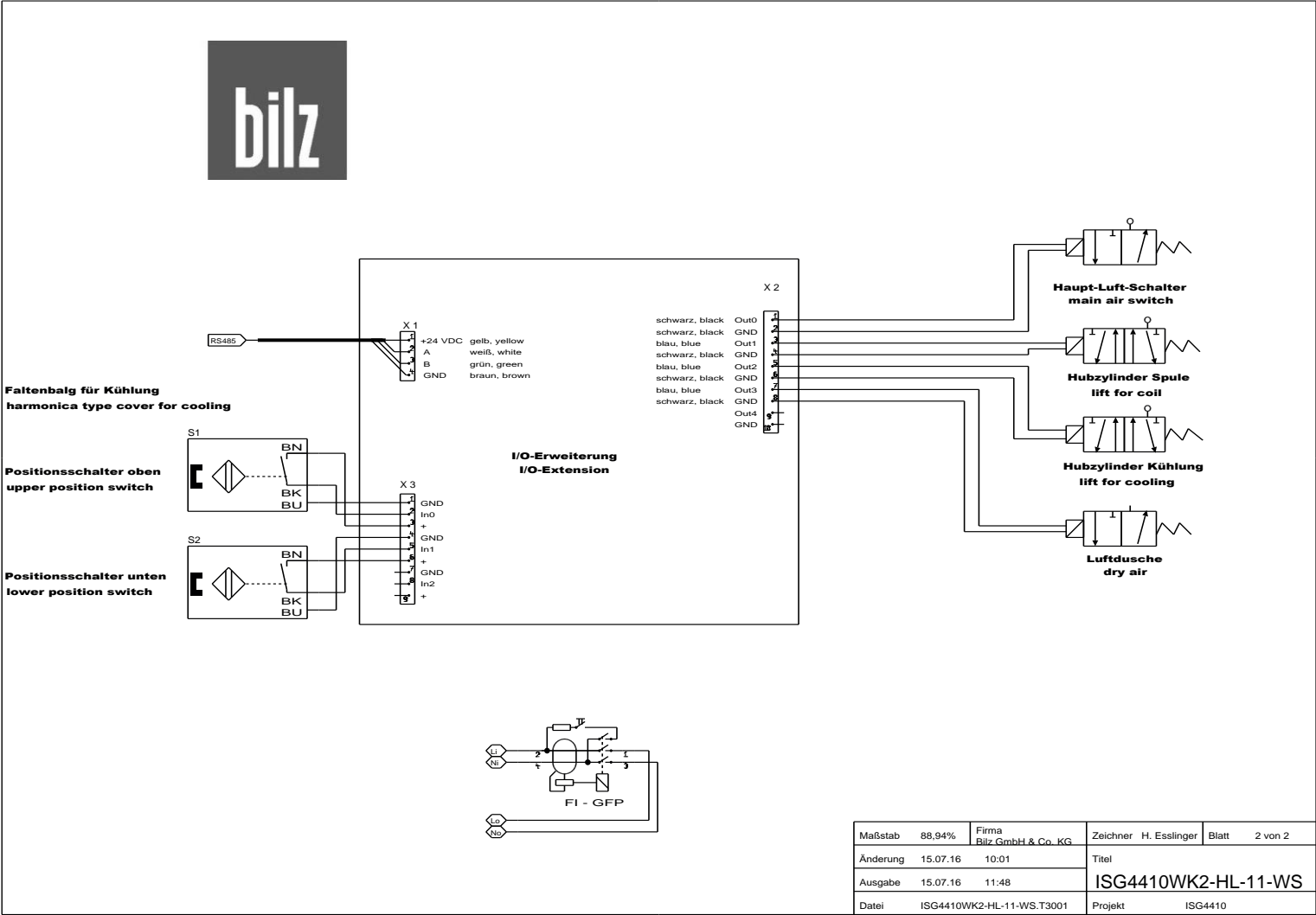

10.10.2 ISG4410WK-HL-480V

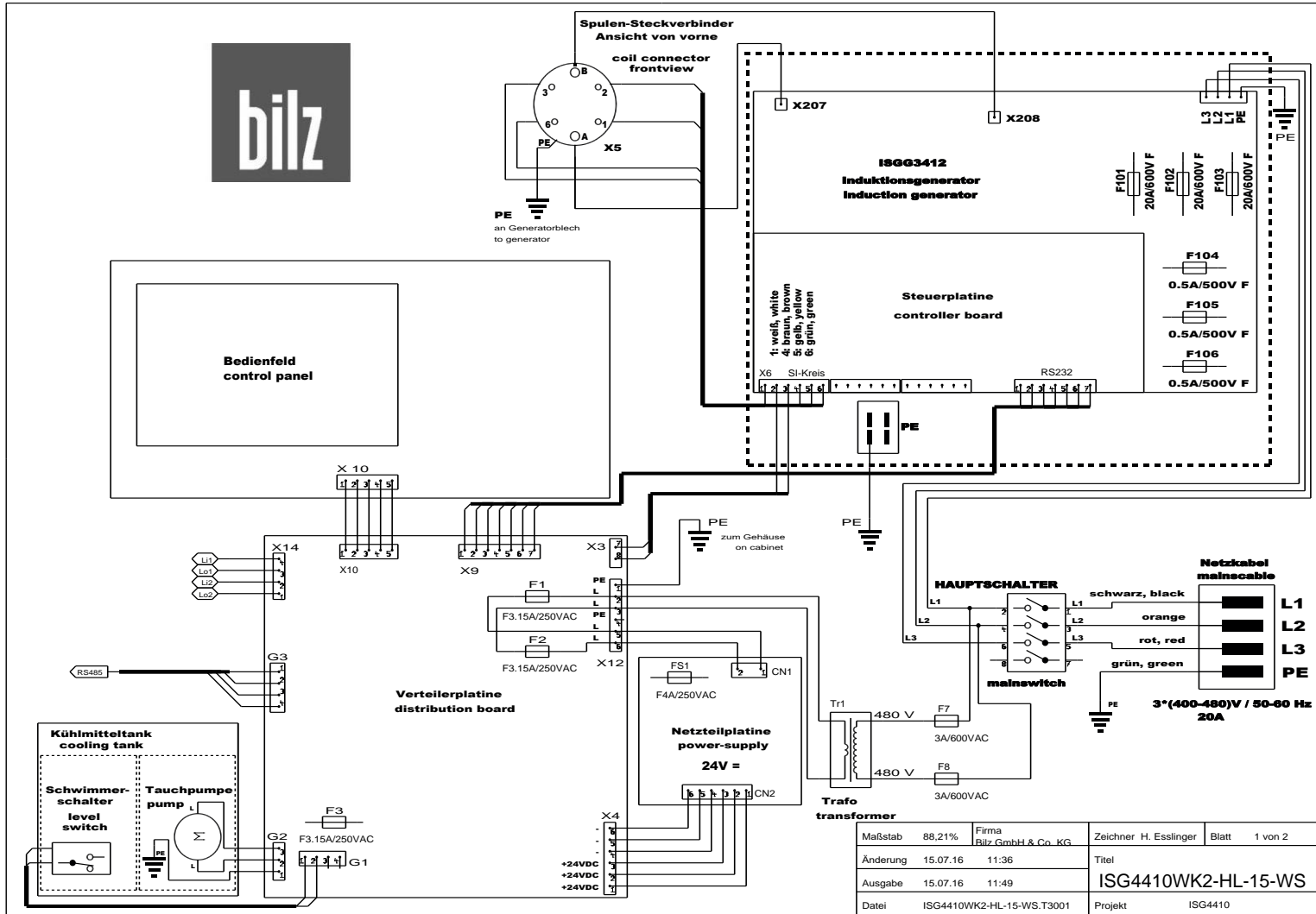

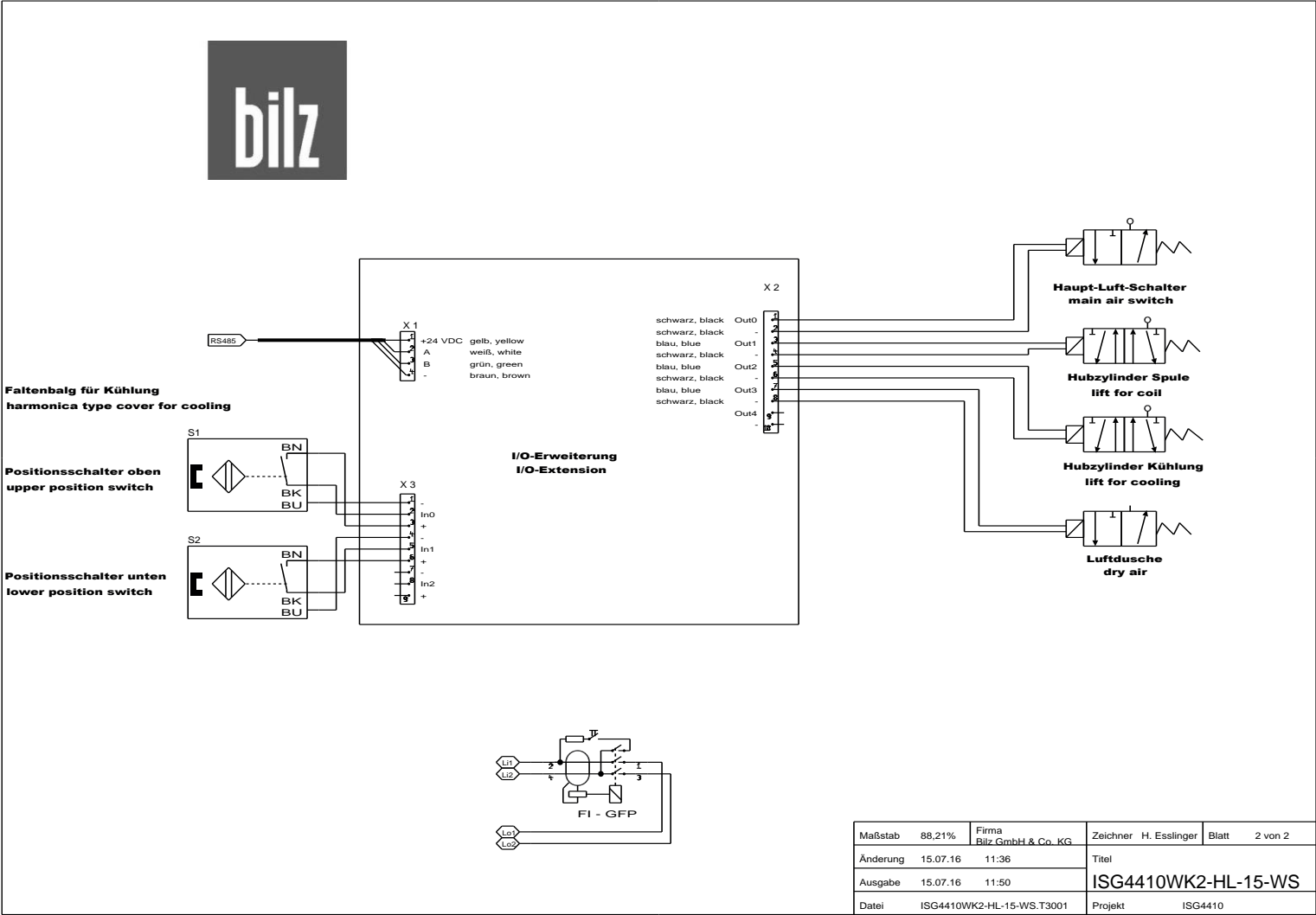

### 10.11 Pneumatic plan ISG4410WK-HL

