

---

**OPERATING MANUAL**  
**ThermoGrip® Induction unit**  
**ISG1000-400V / -208V**

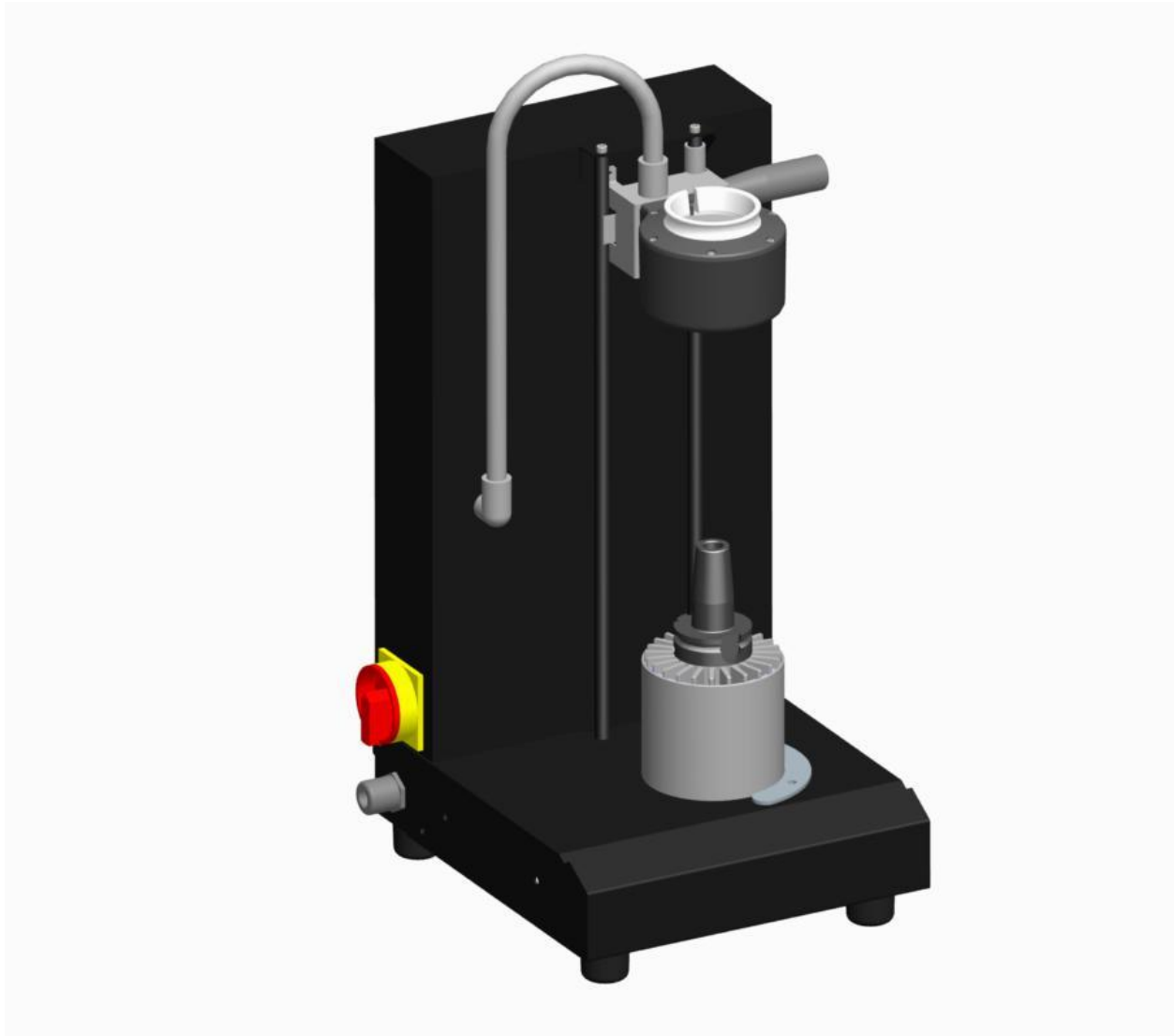

Bilz Werkzeugfabrik GmbH & Co. KG • Vogelsangstrasse 8 • 73760 Ostfildern  
Phone +49 (711) 34801-0 • Fax +49 (711) 348-1256

## Contents

<b>1</b>	<b>Product liability and warranty .....</b>	<b>3</b>
1.1	General .....	3
1.2	Warranty .....	3
1.3	Service .....	4
1.4	Intended purpose.....	4
1.5	Symbols and Pictograms .....	5
<b>2</b>	<b>Safety .....</b>	<b>6</b>
2.1	Selection of the installation site .....	6
2.2	Risks relating to electrical energy .....	6
2.3	Risks from hot parts .....	7
2.4	Protecting the chuck against overheating.....	7
2.5	Risks relating to electromagnetic radiation.....	8
2.6	Special risks.....	8
<b>3</b>	<b>General information about ThermoGrip® .....</b>	<b>9</b>
<b>4</b>	<b>Controls and commissioning ISG1000.....</b>	<b>10</b>
4.1	Assembly .....	10
4.1.1	Setting up the table-top unit ISG1000.....	10
4.1.2	Adjustment of the C-prism .....	10
4.2	Commissioning.....	11
<b>5</b>	<b>Operating the ISG1000.....</b>	<b>12</b>
5.1	Work flow.....	12
5.2	Inserting the chuck.....	12
5.3	Heating process.....	14
5.4	LED display concept.....	15
<b>6</b>	<b>Contacting the Manufacturer .....</b>	<b>16</b>
<b>7</b>	<b>Appendix .....</b>	<b>17</b>
7.1	Technical data .....	17
7.1.1	ISG1000-400V .....	17
7.1.2	ISG1000-208V .....	17
7.2	Overview shaft tolerances .....	17
7.3	Scope of supply .....	18
7.4	Optional Accessory .....	18
7.5	EC Declaration of Conformity .....	19
7.6	Instructions Safety Glove.....	20
7.7	Mains Connections .....	21
7.8	Wiring diagrams.....	22
7.8.1	ISG1000-208V .....	22
7.8.2	ISG1000-400V .....	23

## 1 Product liability and warranty

### 1.1 General

These operating instructions are part of the technical documentation for the ThermoGrip® induction device ISG1000.

These operating instructions are important so that the device can be used safely, correctly and efficiently. Observing these instructions will help to avoid risks, repair costs and downtimes and will raise the general level of performance and the lifespan of the machine. The contents correspond to the constructional status of the ISG1000 at the time these operating instructions were compiled. The construction and technical data is subject to changes due to continuous further developments and for customized models.

Therefore no claims may be made on the basis of the content of these operating instructions (details, charts, drawings, descriptions etc.). Subject to errors!

These operating instructions, in particular the chapter 2 Safety, page 6, must be read and observed by all persons who work with the device:

#### **Operation**

**Including tooling, troubleshooting whilst working, clearing production waste, machine care, disposal of operating supplies and materials**

#### **Maintenance**

**Servicing, inspection, repairs**

#### **Transport**

**In addition to the operating instructions and the accident prevention regulations relevant in the country and the place where the device is used, the recognized technical rules relating to safe and professional work and the respective workshop-specific regulations must be observed.**

If you have any questions, please do not hesitate to call us.

You can contact us at the address stated above.

If the reader discovers any printing errors, ambiguous information or inaccurate information in these operating instructions please let us know.

### 1.2 Warranty

It is expected that the device will remain fully functional, safe and that it will work accurately for many years, however this is only possible if the regulations governing the operation, maintenance and repairs are observed in accordance with the manufacturer's guidance.

Any faults that occur during the warranty period will be remedied as defined in our warranty conditions. Unauthorized modifications and changes expire immediately manufacturer's warranty and all claims resulting from these will be the responsibility of the machine owner. This applies especially for those modifications that impair the safety of the device.

Warranty claims will only be honored if OEM spare and replacement parts are used.

These operating instructions are not a supplement to our terms and conditions of sale and delivery.

### 1.3 Service

We will be happy to help solve problems or perform repairs and modifications that are not described in these operating instructions. Always state the device's serial number in the event of claims, problems or questions.

The serial number is on the type plate on the side of the device.

### 1.4 Intended purpose

The ThermoGrip® induction device ISG1000 is used for the thermal engagement and disengagement of tools in shrink chucks.

Any other use above and beyond this is deemed not in accordance with the intended use. We will not be liable for any resulting damage. The operator bears the full risk.

Intended use also includes observing the operating instructions and compliance with the stipulated inspection and servicing intervals.

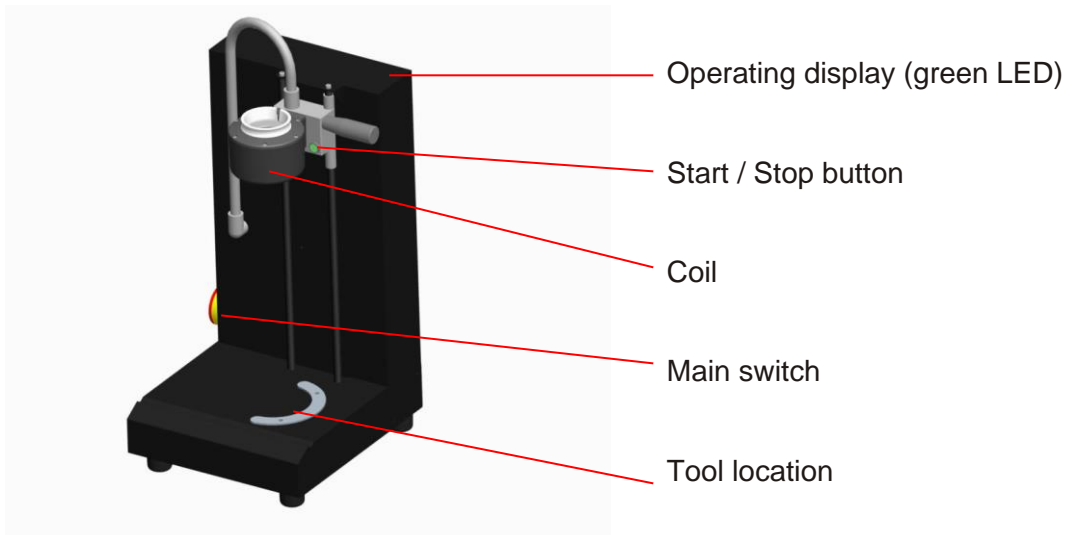

**Figure 1**  
ThermoGrip® induction device ISG1000

## 1.5 Symbols and Pictograms

**Warnings** are marked by warning triangles with hazard symbols to warn about risks that could result in damage to property or personal injury.



**Warning!** Potentially fatal risk or risk of serious injury!  
Non-observance may lead to death or serious injury!



**Caution!** Risk of minor injury!  
Non-observance may lead to minor injury!

**Information!** Information about how to carry out an action effectively and to avoid damage.

**Instructions** are marked by circles with hazard symbols or triangles with instruction specifying that an action needs to be carried out or that specific items need to be used.



**Goggles** Risk of damage to the eyes!  
**Wear goggles! During the heating phase it is possible that parts of the heated metal surfaces splitter off and cause injuries!**



**Gloves** Risk of injury!  
**Sharp edges or metal chips adhered to the tool can cause injury, therefore protective gloves must be worn!**

**Activities** are marked by the symbol ➤ and state the action that needs to be carried out. The result of the activity may be stated beneath the symbol for clarification purposes.

Example:

- Lower coil
- Start shrinking process
- Remove tool

## 2 Safety

The induction generator has been built to comply with the state-of-the-art design at the time of delivery and is safe to operate. Nevertheless, there are still risks involved with operating the device if it is used by untrained or unqualified personnel or if it is not used as intended. Therefore, must be observed:

**Please read the operating instructions carefully and familiarize yourself with the operating elements before commissioning and using the device!**

The operating instructions are an integral part of the function of the induction generator and must be easily accessible, legible and available in full to all persons who work with the system.

The device may only be operated by trained and competent personnel!

The device may only be used for its intended purpose and only when it is in a fully functional state!

The induction generator is designed and suited for ThermoGrip® chucks. Problems may arise when unshrinking / shrink-fitting other chuck types leading to damage to the chucks or to the induction device itself.

All unauthorized modifications will expire immediately the manufacturer's warranty. The operator bears the sole risk of injury to the user or third parties and for any damage to the induction generator or other elements of the device!

### 2.1 Selection of the installation site

The ISG1000 is designed as a table-top device and must be positioned safely in a dry and clean place which is not exposed to vibrations.

Protect against dust, dirt and splash water!

Avoid direct sunlight to improve the legibility of the green LED.

### 2.2 Risks relating to electrical energy

The device has live parts inside which are dangerous if touched.

Please observe the following safety points:

- The device must not be operated when the housing is open!
- The device must only be opened by our service personnel or under strict manufacturer's guidance!
- Keep the device clean. Clean regularly!
- Never use compressed air to clean the machine or tool holders nearby the machine, to prevent chips from being forced to electronics circuits

## 2.3 Risks from hot parts

The very effective heating function only heats the relevant surface zones of the chuck with the lowest heat input possible. The surface of the heated chucks reaches temperatures of up to 400°C. The coil and the cutting tool hardly heats up at all when operated properly.



**Caution! Risk of injury caused by burns from hot parts!**



As a result of the shrinking process the heated tool assembly radiates heat. Therefore, the heated chuck must be cooled in a timely manner to avoid risk of injury and damage to the coil!



**Ensure that only shrink-fit chucks are used. There is a risk of injury if other chucks, especially hydraulic clamping chucks, are heated up!**

Do not interrupt the automatic cooling of the shrink chuck following the shrinking process!

For your own safety, follow the safety instructions below when working with the device:

- The device may not be operated in an explosive environment!
- Do not use easily ignitable, solvent-based, or corrosive cleaning agents!
- Ensure that hot parts cannot be touched accidentally!
- Always wear the gloves supplied when unshrinking/ shrink fitting the tools to protect your hands from burns and cuts!
- Place hot tools on non-flammable, heat-resistant surfaces!
- Apart from the chuck and the tool, do not allow any metal objects inside the induction coil as these will also become hot!
- Never reach into the heating area of the coil during operation as rings or chains can also heat up very quickly!
- Always wear protective eyewear during shrinking! Bits of the tools or chuck can break off during the heating process and cause injuries!

## 2.4 Protecting the chuck against overheating

If the shrinking process is too long or if the chuck is reheated several times within a short period without correct cooling, the chuck and tool may overheat. Therefore, always keep the heating times as short as possible during shrink fitting.

Avoid overheating the chuck or repetitive cycles without correct cooling times!

Never re-heat a chuck that has not cooled down to room temperature.

## 2.5 Risks relating to electromagnetic radiation

If used correctly, the device does not emit any electromagnetic radiation that is dangerous to its environment. The radiation safety of the system is checked and verified through tests performed in accordance with EC Machinery Directive (see 7.5 EC Declaration of Conformity, page 19).



**The shrinking process must not be operated without the ferrite disc being inserted!**

If the induction heating is started when there is no ferrite disc being inserted in the coil, the magnetic field also affects the area close to the coil.



**The shrinking process must not be operated without chuck being inserted!**

If the induction heating is started when there is no chuck in the coil, the magnetic field also affects the area close to the coil.



**Warning!**

**Potentially fatal risk for people with implants, especially with pacemakers!**



If you have an implant, in particular a pacemaker, keep at least 3 m away from the device until you have checked with the manufacturer or your doctor that the implant is not affected by the induction field.

## 2.6 Special risks

### **Risk of crushing and cuts in the coil's range of motion!**



Ensure that no parts of your body or objects are in the range of motion of the coil whilst the induction device is operating. The weight of the coil can cause crushing injuries and cuts in connection with the cutting tools.

### **Damage of the coil and/ or the electric installment**

By using Non-ThermoGrip® or too large shrink chucks, the hot chuck may touch the coil and destroy the isolation. In case of any damage of the coil and/ or the electric installment, the device has to be stopped immediately and the manufacturer has to be contacted.



**Do not operate the machine with a damaged coil, high voltage is present inside.**



### 3 General information about ThermoGrip®

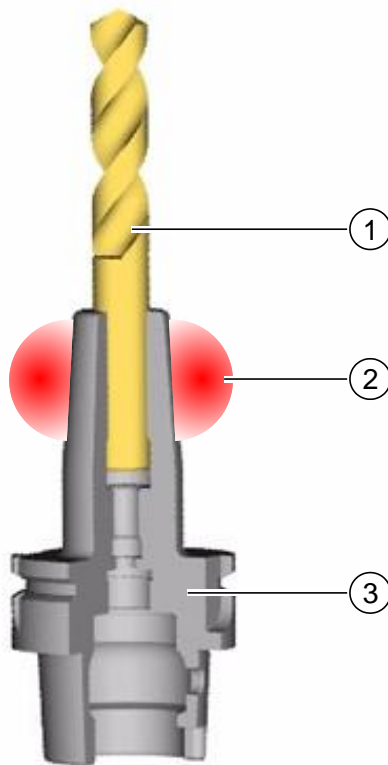

Shrinking has been known as a technique for achieving non-detachable connections, and offers remarkable advantages for chucking tools. By the **inductive heating with high energy density**, tools can be changed in a matter of seconds.

A cylindrical tool (1) is pushed into a heated and expanded bore of the chuck; after the chuck has cooled, a high radial clamping force is applied. When handled properly, the clamping operation is reversible and can be repeated as often as required. The possible clamping forces are higher than any conventional clamping techniques.

**Only shrink using clean tools in cleaned chucks!**

**Micro processor controlled  
Induction generator ISG1000**

With the help of special coils, only the specific clamping area (2) of the chuck (3) is heated.

A special housing / shield surrounding the coil prevents magnetic flux to a large extent. The control components and the high frequency generator are integrated in the housing.

**Figure 2**  
Shrunk-in tool

All cables go through a protective hose. The coils have a high electric loading of up to 35A induction current and up to 1000V voltage. The power has a short and partial impact on the clamping area. Therefore little energy is induced into the clamping chuck.

#### **Advantages of ThermoGrip® clamping technology at a glance:**

- Quick shrinking times in and out
- High clamping forces
- Higher tool and spindle life due to small run-out (< 3 μm)
- Good surface finish due to high rigidity of the tool clamping system
- High flexural yield strength and radial clamping strength and stability also with long body lengths
- Slim body of the chucks for high speeds
- Only localized yet homogeneous heating of the chuck
- Fastest possible cooling time of the tool and chuck
- Specific heat-resistant steel give the chucks a high tool life and makes them dimensionally stable

## 4 Controls and commissioning ISG1000

### 4.1 Assembly



**Caution:**

Ensure that the unit is not damaged during the unpacking process.

#### 4.1.1 Setting up the table-top unit ISG1000

Choose a suitable place (see 7.1 Technical data, Environmental conditions, page 17) for the ISG1000 e.g. a plane solid table top.

This table-top unit does not have vertically adjustable mounting feet and align themselves automatically with the plane table top.

#### 4.1.2 Adjustment of the C-prism

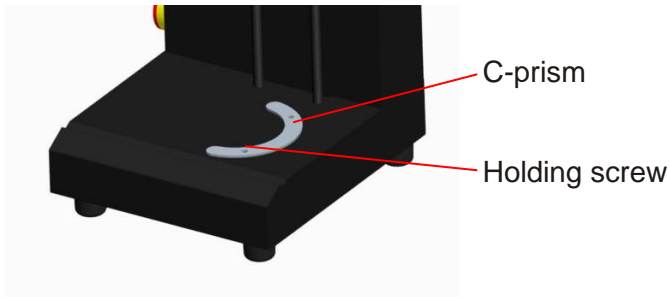
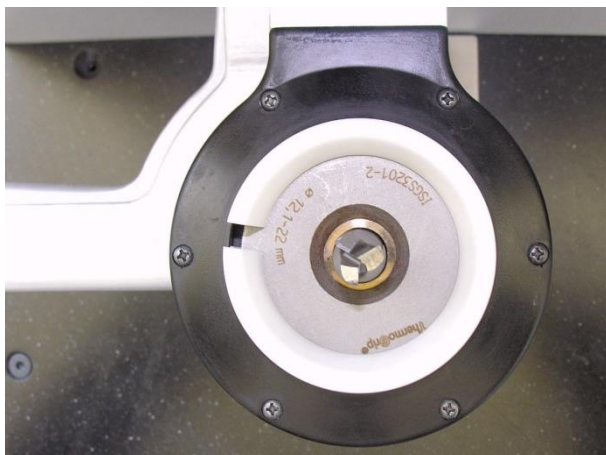

**Figure 3**

C-prism below the induction coil with holding screws and position of the tool holder

The C-prism ensures that a chuck is in the correct shrinking position as soon as its tool holder is positioned into the C-prism location. The C-prism has to be adjusted so that the tool and/or the shrinking chuck cannot touch the coil.

Proceed as follows to adjust:



- Insert a tool with a small diameter and the matching ferrite disc.
- Carefully lower the coil and centre the tool.
- Unscrew the holding screws of the C-prism.
- Move the C-prism so that the tool holder sits in the final position on the C-prism when the tool is dead-centered.
- Tighten the holding screws of the C-prism.

When the tool holder is in the final position of the C-prism, it is correctly positioned.

**Figure 4**

Coil positioned on over the top of the chuck centre, in the picture with the correctly centred tool.

### 4.2 Commissioning

- Choose an installation site which ensures that the ventilation slits on the bottom of the device are not covered.
- Place the device on an even surface and ensure it has a sturdy base to sit on.
- Move the coil with the handle up and down to check its mobility.

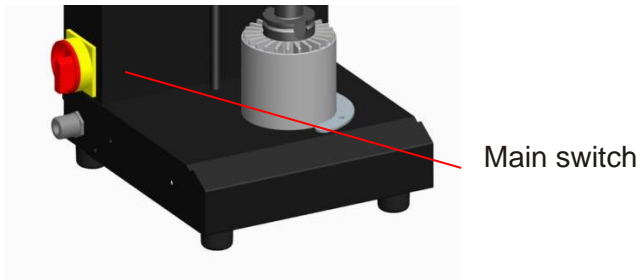

**Figure 5**  
Power supply

- Connect the power supply
- Switch on the main switch
- The green LED (operating display) is on to show that the device is operational.

## 5 Operating the ISG1000

### 5.1 Work flow

A shield around the coil largely prevents magnetic stray fields. The control system and the high-frequency generator are integrated inside the housing. Only one coil is required for all shrink diameters. All the cables to the mobile coil are protected.

The operator lowers the weight-compensated coil manually onto the chuck and then moves it upwards again after the shrinking process. Immediately after this, cool the hot chuck to avoid the chuck or assembly heating up.

For your own safety, observe the following rules when working with the ISG1000:



**Goggles Risk of damage to the eyes!**

**Wear goggles! During the heating phase it is possible that parts of the heated metal surfaces splinter off and cause injuries!**



**Gloves Risk of injury!**

**Sharp edges or metal chips adhered to the tool can cause injury, therefore protective gloves must be worn!**

Due to the required shrinking temperatures, only move the chuck whilst in the matching tool holder until it has cooled down and always wear gloves. Never touch the chucks without wearing the protective gloves. Only touch the chucks on the machine connection and not in the heated zone! The maximum holding time even when wearing the protective gloves is 5 seconds!

### 5.2 Inserting the chuck



- Move the coil into the upper end position.
- Fit the cover plate that matches the chuck into the coil. Observe the type and locking diameter or the chuck (see chapter 7.1 Technical data, page 17).
- Place the chuck in the matching tool holder (T3-W...) until it reaches the C-prism location below the linear guide.

**Figure 6**  
Correctly positioned tool holder with chuck and tool

## Operating the ISG1000

---

**Note!** If the opening in the cover plate is too large this can lead to the tool heating up. If the opening is too small, this may lead to damage to the tool and/or cover plate.

**Note!** The size of the counter-bore is only a few hundredths of a millimeter larger than the nominal shank size. Therefore only insert tools with ground shaft as defined (see 7.2 Overview shaft tolerances, page 17)

Tools with larger shaft tolerances cannot be locked into position safely!

Only insert clean, grease-free shafts into the chuck to achieve the best locking pressures.

**Note!** If wet tools are used, the heating process can cause sudden evaporation which may lead to injury caused by splashing liquid. As a result, it is possible that the tool cannot be used or is damaged. Therefore only use dry tools!

**Note!** Ensure that the tool shafts that are used in the clamping area are free from damage!

Ensure that the chucks are positioned safely and straight in the tool holders.

Otherwise the tool and/or the coil could become damaged when the coil is lowered !

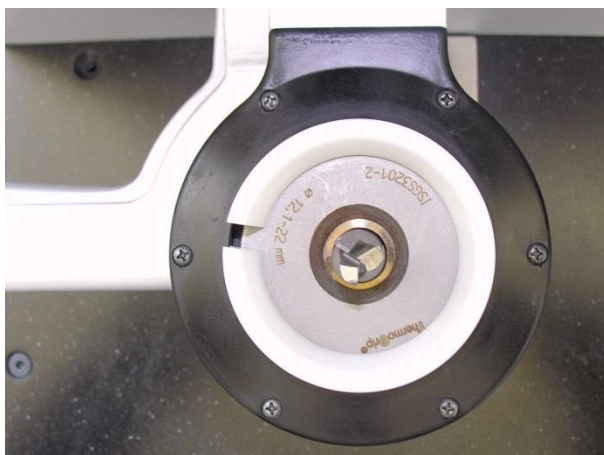

➤ Manually feed the coil downwards over the chuck until the lower edge of the ferrite disc of the coil lies on the chuck.

**Figure 7**

Coil in place; in the picture, the tool for unshrinking

### 5.3 Heating process

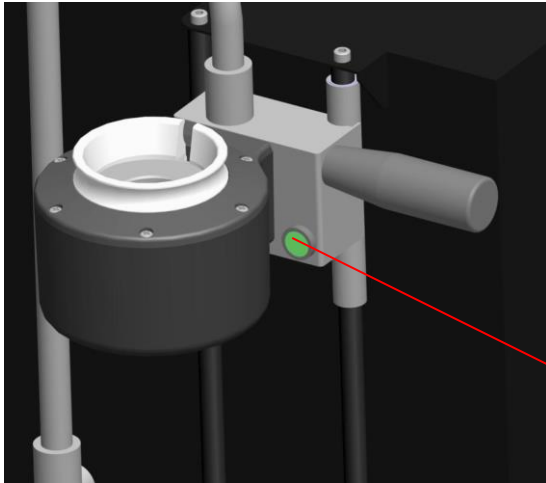

- For shrink fitting: Place the tool in the correct position. In suitable BILZ systems, the tool can be pre-mounted to ensure correct alignment and safe shrinking operation.
- For unshrinking: The tool can be extracted from the chuck during the unshrinking process by apply light pulling pressure, always ware the protective gloves during this process to avoid injury from new or used cutting edges.

Start / Stop button

**Figure 8**  
Coil with Start / Stop button



#### **Gloves Risk of injury!**

**Sharp edges or metal chips adhered to the tool can cause injury, therefore protective gloves must be worn!**

Always wear protective gloves due to the high shrinking temperatures. Only touch chucks when wearing gloves and only on the machine connection and never in the heated zone!  
The maximum holding time should never exceed 5 seconds even when wearing gloves!

**Note!** As soon as the shrink / unshrinking process has been completed successfully, the heating process must be stopped by releasing the Start / Stop button to ensure that no excess energy is transferred to the chuck and the tool assembly. As a result, the cool-down time is much shorter.

- Lift the coil and place the shrink chuck into the tool holder.
- Move the coil downwards over the chuck so that the lower edge of the ferrite disc of the coil lies onto the chuck.
- In the case of tools to be shrunk into ThermoGrip® chucks, you can insert the tools 5 mm deep into the counter-bore of the chuck.
- Start the shrinking process by pressing the Start / Stop button. The operating display (green LED) flashes.
- The shrinking time is determined by pressing the Start / Stop button. The shrinking process is finished by releasing the Start / Stop button.
- After the end of the shrinking process, lift the coil and remove the shrink holder. Allow the tool and chuck to cool down.
- During unshrinking process, remove the tool from the chuck by pulling upwards slightly. Place the tool on a heat-resistant surface.
- Always ensure that any persons in the vicinity are protected from accidentally touching the hot chuck and/or hot tool.

### 5.4 LED display concept

There is an LED in the upper right area of the ISG1200 for the operating status display. The operating state is coded as follows:

LED Status	Status	Procedure
<b>LED On</b>	<b>Ready for operation</b>	Waiting for a valid input of parameters by barcode.
<b>LED flashes</b> On 0.25 sec. Off 0.25 sec.	<b>Induction process running</b>	If you use predefined parameters, the heating process stops automatically after the set time is reached. If you use manual parameters, the heating process stops when you release the actuation switch.
<b>LED pulses</b> 2 pulses	<b>Error</b> Si-circuit error or Overtemperature error.	Switch off the device and test the functionality after 15 minutes. If the error still occurs, please contact your service partner.
<b>LED pulses</b> 3 pulses	<b>Error</b> Overvoltage error or Overcurrent error or Overcoil current error.	Switch off the device and test the functionality after 15 minutes. If the error still occurs, please contact your service partner.
<b>LED pulses</b> 4 pulses	<b>Error</b> Other errors.	Switch off the device and test the functionality after 15 minutes. If the error still occurs, please contact your service partner.
<b>LED Off</b>	<b>Error</b> Missing voltage supply or serious error.	Check whether the main switch of the device is switched on. Check the power supply to the machine. If the error still occurs, please contact your service partner.

### **6 Contacting the Manufacturer**

These operating instructions can only serve to generally describe the function and operation of the ThermoGrip® induction generator.

To solve special problems and to carry out repairs or to make any changes not described in these operating instructions, please contact the below mentioned company who will be pleased to help you.

In case of problems or enquiries, please note the unit serial number. The serial number is located on the rating disc on the back of the unit.

Contact us at:

**Bilz Werkzeugfabrik GmbH & Co. KG**

**Vogelsangstrasse 8**

**73760 Ostfildern**

**Germany**

**Phone +49 (711) 34801-0**

**Fax +49 (711) 348-1256**

**[www.bilz.de](http://www.bilz.de)**

Up-to-date news about ThermoGrip® can also be found on the internet site.



## 7 Appendix

### 7.1 Technical data

#### 7.1.1 ISG1000-400V

Induction device	ISG1000-400V
Voltage:	3 x 400 V / 50 Hz
Charging rate, maximal:	3 x 16 A
Nominal power:	8 kW

#### 7.1.2 ISG1000-208V

Induction device	ISG1000-208V
Voltage:	3 x 208 V / 50-60 Hz
Charging rate, maximal:	3 x 12 A
Nominal power:	3.2 kW

Mass:	17 kg
-------	-------

#### Dimensions:

Depth:	390 mm
Width:	310 mm
Height:	640 mm

#### Environmental conditions:

Temperature	+5°C ... +40°C (+40°F ... +105°F)
Relative humidity	5% ... 85%, no condensation, no icing
Air pressure	86kPa ... 106kPa



### 7.2 Overview shaft tolerances

The following shank tolerances are required for the various shank diameters:

Shank Ø	Shank Tolerance	Type of Tool
3mm	h4	Carbide
4mm	h4	Carbide
5mm	h5	Carbide
≥6mm	h6	Carbide or HSS

### 7.3 Scope of supply

Shrinking Unit ISG1000 incl. coil and 1 ferrite disc, clamping ring, gloves.

Ferrite disc 	For an optimal shielding of the magnetic field between coil and tool shank		
	Clamping-Ø	Designation	Ident No.
	6,0 – 16,0 mm	ISGS1001-2	5094533
Clamping ring 	For a secure support of the ferrite disc in the coil		
		Designation	Ident No.
		ISGS309	6950431
Gloves 	For the protection from possible burns and cuts		
		Designation	Ident No.
		VA662-10	6947666

### 7.4 Optional Accessory

Ferrite disc 	For an optimal shielding of the magnetic field between coil and tool shank		
	Clamping-Ø	Designation	Ident No.
	3,0 – 5,9 mm	ISGS2201-1	6725758

## 7.5 EC Declaration of Conformity

### In accordance with the EC Machinery Directive 2006/42/EC

Bilz Werkzeugfabrik GmbH & Co. KG

declares, that the machine designated below corresponds to the following relevant directives with regard to its design and construction in the version brought into circulation.



Designation of the machine:	Induction unit
Machine type:	ISG1000
Relevant EC directives:	EC Machinery Directive 2006/42/EC EC EMC Directive 2014/30/EC
Applied harmonized standards, in particular:	EN ISO 12100:2010 EN 60204-1:2006+A1:2009 EN 61000-6-2:2005 EN 61000-6-4:2007 + A1:2011 EN 55011:2009 + A1:2010 EN 60519-1:2011 EN 60519-3:2005
Applied national standards (USA):	FCC 47 CFR Ch. I (Edition 10-1-01), Part 18 C

In the event of any changes to the machine for which we have not been consulted, this statement becomes null and void.

#### THE COMPANY:

Company name:	Bilz Werkzeugfabrik
Legal form of company:	GmbH & Co. KG
Founding year:	1919
Register of companies:	HRA 210313, Amtsgericht Stuttgart
Headquarters:	Vogelsangstrasse 8 73760 Ostfildern Germany
Phone:	+49 (711) 34801-0
Fax:	+49 (711) 348-1256
E-Mail:	vertrieb@bilz.de
Internet:	www.bilz.de
Name of authorized representative of the technical documentation:	Bilz Werkzeugfabrik GmbH & Co. KG
Ostfildern, November 2023	
General Manager:	Michael Voss



## 7.6 Instructions Safety Glove

**Description:** Heat protection glove, outer layer consisting of para aramide yarn (KEVLAR)  
Fine knitted fabric lined with aramide felt and 100% Nornex knitted fabric

**Availability:** Size 10

**Color:** yellow

**Manufacturer:** JUTEC GmbH, Mellumstr. 23-25, D-26125 Oldenburg

**Description:** These gloves have been designed to protect your hands. They are made of the materials named above. The characteristic features of these gloves are their long service life and outstanding comfort.

**Category:** 

**Instructions:** Check that the gloves offer suitable protection for the activity you are currently performing. Select the gloves to fit the size of your hands. Remove the gloves from the wrapping.

When using the gloves, pay attention to the following points:

The maximum touching time depends on the area touched.  
For safety reasons this time should never exceed 5 sec.

The open structure of these gloves means that they cannot protect your hands from punctures and impacts from pointed objects. Penetration by liquids is also possible. For protection from chemicals, gloves resistant to such substances should be worn over these gloves. Oil, grease and moisture reduce the resistance of all gloves to cutting damage and should be avoided. KEVLAR gloves are resistant to tearing. Do not use these gloves near machines with moving parts, as your hands could get pulled into the machine.

**Care and repairs:** KEVLAR gloves can be dry-cleaned or washed according to the instructions on the label. Wash in water and mild detergent at maximum 40°C. DO NOT USE softening agents, bleach or oxidizing agents, as these weaken the aramide fibers and reduce the cut-resistance of the gloves. After washing the gloves, check them carefully for any cuts and worn places. Do not use gloves which are damaged too much and can no longer be repaired, as these no longer offer adequate protection.

**Storage:** The gloves should be kept in their original wrapping in a dry, clean place. Avoid exposing the gloves to moisture or high temperatures.

**Warning:** The degree of protection required by a special task depends on the risks involved. You yourself bear final responsibility for selection of the best safety equipment for the risks involved in your workplace. Please check whether this article offers adequate protection for the jobs of work you have to perform. We offer a whole range of cut- and heat-proof KEVLAR gloves for high-risk jobs of work.

## 7.7 Mains Connections

### Connection socket of ISG1000-400V

#### Allocation of the CEE socket

Pin name	Pin designation	Wire colour
L1	Phase L1	Brown
L2	Phase L2	Black / grey
L3	Phase L3	Black
N	Neutral	Blue
PE	Ground	Green-yellow

The nominal voltages between the phases are 3x400V (-10/+10%)

Measurement between the pins		Voltage (VAC)
N → L1	PE → L1	230
N → L2	PE → L2	230
N → L3	PE → L3	230
L1 → L2		400
L1 → L3		400
L2 → L3		400



#### Further hints:

- Connecting the protected earth PE and connecting the neutral N is essential!
- If an earth-leakage circuit breaker (GFI, GFCI) is used for the protection of the CEE-socket, it must be 4-polar.

## 7.8 Wiring diagrams

### 7.8.1 ISG1000-208V

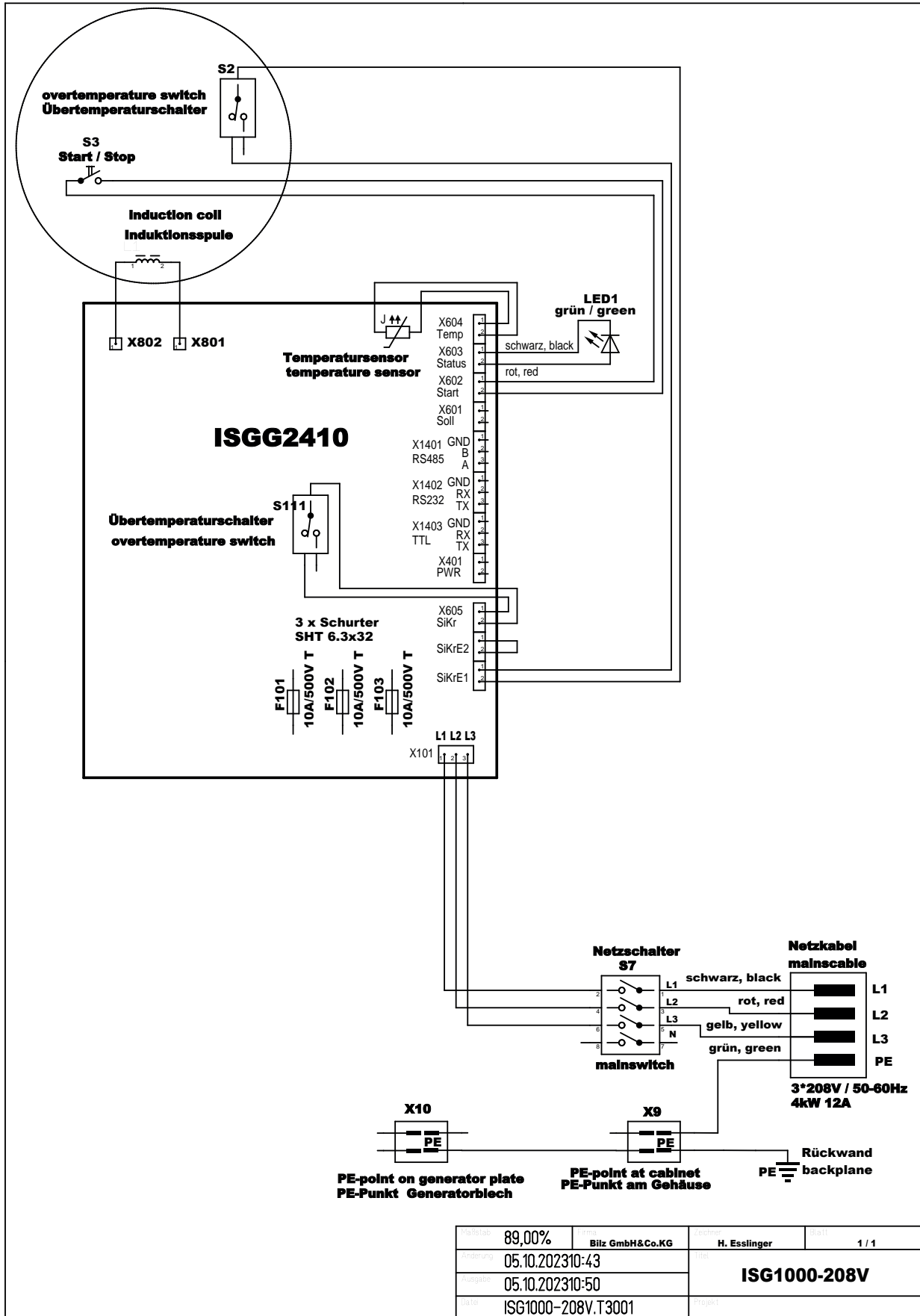

7.8.2 ISG1000-400V

