

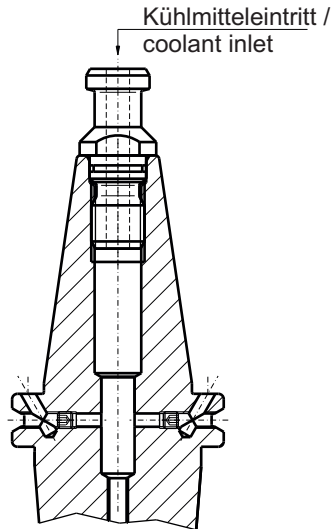

Umstellung des Kühlmiteleintritts am Steilkegel DIN-ISO 7388-1(2) mit Anzugsbolzen DIN-ISO 7388-3

Modification of the coolant inlet at taper shank DIN-ISO 7388-1(2) with retention knob DIN-ISO 7388-3

“D”



Auslieferungszustand
Delivery condition

“F”

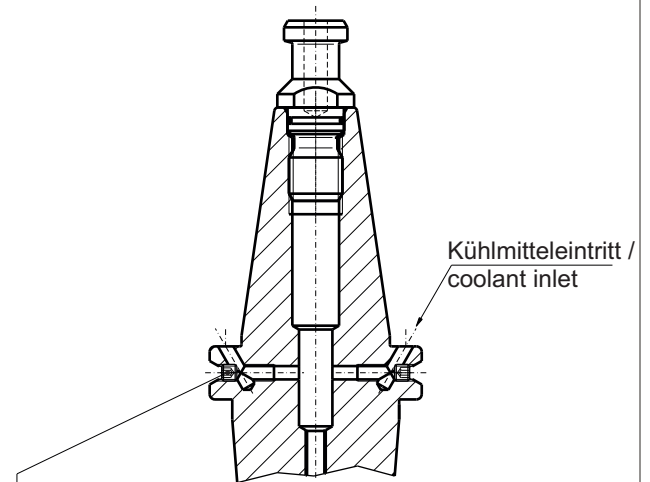

Schraube kühlmitteldicht mit Loctite 577 oder 542 eingeklebt /
Set screws sealed by using Loctite 577 or 542